

# UD18-22CC242

UD18

**FORK SENSORS**

**SICK**  
Sensor Intelligence.

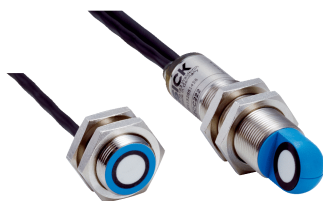
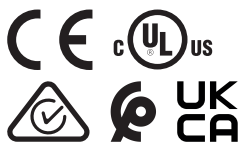

Illustration may differ



## Ordering information

Type	part no.
UD18-22CC242	6058913

Other models and accessories → [www.sick.com/UD18](http://www.sick.com/UD18)

## Detailed technical data

### Features

<b>Functional principle</b>	Ultrasonic detection principle
<b>Housing design</b>	Cylindrical
<b>Dimensions (W x H x D)</b>	18 mm x 18 mm x 79.2 mm
<b>Installation distance</b>	20 mm ... 60 mm, 40 mm ± 3 mm (default setting)
<b>Fork width</b>	60 mm (corresponds to max. mounting distance)
<b>Blind zone</b>	7 mm ... 7 mm (from sender and receiver)
<b>Permissible angle deviation</b>	± 45° perpendicular to material layer
<b>Detectable material</b>	Paper with grammages: 20 g/m <sup>2</sup> ... 2,000 g/m <sup>2</sup> Plastic sheets and foils: ≤ 0.4 mm Self-adhesive films, metal sheets: ≤ 0.3 mm Corrugated cardboard: single wall F, N and G flute sizes Washi Wafer PCB
<b>Label detection</b>	✓
<b>Resolution</b>	1 material layer
<b>Display</b>	2 x LED
<b>Adjustment</b>	Cable (Control inputs C1, C2, C3)
<b>Additional function</b>	3 selectable sensitivity levels Teach-in of up to 4 individual sensitivity level Sensitivity level changeover during operation Configurable via IO-Link, SOPAS and Connect+ software
<b>Output time</b>	2 ms, trigger mode: < 0.5 ms
<b>Safety-related parameters</b>	
	MTTF <sub>D</sub> 101 years

### Interfaces

<b>Digital output</b>	Q <sub>1</sub> , Q <sub>2</sub>
Number	2 <sup>1) 2)</sup>
Type	NPN

<sup>1)</sup> Outputs Q<sub>1</sub> and Q<sub>2</sub> short-circuit protected.

<sup>2)</sup> NPN: Active ≤ 2 V / Inactive = Vs.

Function	Q <sub>1</sub> : Double layer digital output, Q <sub>2</sub> : No material / single layer digital output, normally closed contact in each case
Maximum output current I <sub>A</sub>	≤ 200 mA
<b>Control input</b>	3 x (active ≥ 18 V, deactivated ≤ 13 V or inputs not connected)

<sup>1)</sup> Outputs Q<sub>1</sub> and Q<sub>2</sub> short-circuit protected.

<sup>2)</sup> NPN: Active ≤ 2 V / Inactive = V<sub>s</sub>.

## Electronics

<b>Supply voltage</b>	20 V DC ... 30 V DC <sup>1)</sup>
<b>Ripple</b>	± 10 %
<b>Current consumption</b>	50 mA <sup>2)</sup>
<b>Power consumption</b>	≤ 1.5 W <sup>2)</sup>
<b>Initialization time</b>	< 750 ms
<b>Ultrasonic frequency</b>	400 Hz
<b>Switching frequency</b>	250 Hz
<b>Response time</b>	2.5 ms
<b>Switching output</b>	NPN
<b>Switching output (voltage)</b>	NPN: HIGH = V <sub>S</sub> / LOW ≤ 3 V
<b>Output current I<sub>max</sub></b>	≤ 100 mA
<b>Protection class</b>	III <sup>3)</sup>
<b>Circuit protection</b>	U <sub>V</sub> connections, reverse polarity protected Output Q short-circuit protected
<b>Connection type</b>	
Supply voltage & I/O	Cable open end, 7-wire, 2 m
<b>Connection type Detail</b>	
Length of cable	2 m
Cable material	PUR
Cable diameter	4.4 mm
Conductor cross section	0.25 mm <sup>2</sup>
<b>Pinouts for Supply voltage &amp; I/O</b>	
BN	+ (L+)
BK	Q <sub>1</sub> / Q <sub>1</sub>
BU	- (M)
WH	Q <sub>2</sub> / Q <sub>2</sub>
VT	C1
PK	C2
GY	C3/COM

<sup>1)</sup> Limit values, reverse-polarity protected, operation in short-circuit protected network: max. 8 A.

<sup>2)</sup> Without load.

<sup>3)</sup> Reference voltage DC 50 V.

## Mechanics

<b>Sending axis</b>	Angled
<b>Thread size</b>	M18 x 1

<b>Housing material</b>	Nickel-plated brass, PBT/PA
<b>Sensing face material</b>	Ultrasonic transducer: polyurethane foam, glass epoxy resin
<b>Weight</b>	Approx. 130 g

## Ambient data

<b>Ambient operating temperature</b>	+5 °C ... +60 °C
<b>Ambient temperature, storage</b>	-40 °C ... +85 °C
<b>Shock load</b>	According to EN 60068-2-27
<b>EMC</b>	EN 60947-5-2 <sup>1)</sup>
<b>Enclosure rating</b>	IP65
<b>UL File No.</b>	NRKH.E191603 & NRKH7.E191603

<sup>1)</sup> The sensor complies with the electromagnetic compatibility (EMC) requirements for the industrial sector (Radio Safety Class A).

## Certificates

<b>EU declaration of conformity</b>	✓
<b>UK declaration of conformity</b>	✓
<b>ACMA declaration of conformity</b>	✓
<b>Moroccan declaration of conformity</b>	✓
<b>China RoHS</b>	✓
<b>cULus certificate</b>	✓

## Classifications

<b>ECLASS 5.0</b>	27270909
<b>ECLASS 5.1.4</b>	27270909
<b>ECLASS 6.0</b>	27270909
<b>ECLASS 6.2</b>	27270909
<b>ECLASS 7.0</b>	27270909
<b>ECLASS 8.0</b>	27270909
<b>ECLASS 8.1</b>	27270909
<b>ECLASS 9.0</b>	27270909
<b>ECLASS 10.0</b>	27270909
<b>ECLASS 11.0</b>	27270909
<b>ECLASS 12.0</b>	27270909
<b>ETIM 5.0</b>	EC002720
<b>ETIM 6.0</b>	EC002720
<b>ETIM 7.0</b>	EC002720
<b>ETIM 8.0</b>	EC002720
<b>UNSPSC 16.0901</b>	39121528

Dimensional drawing, sensor

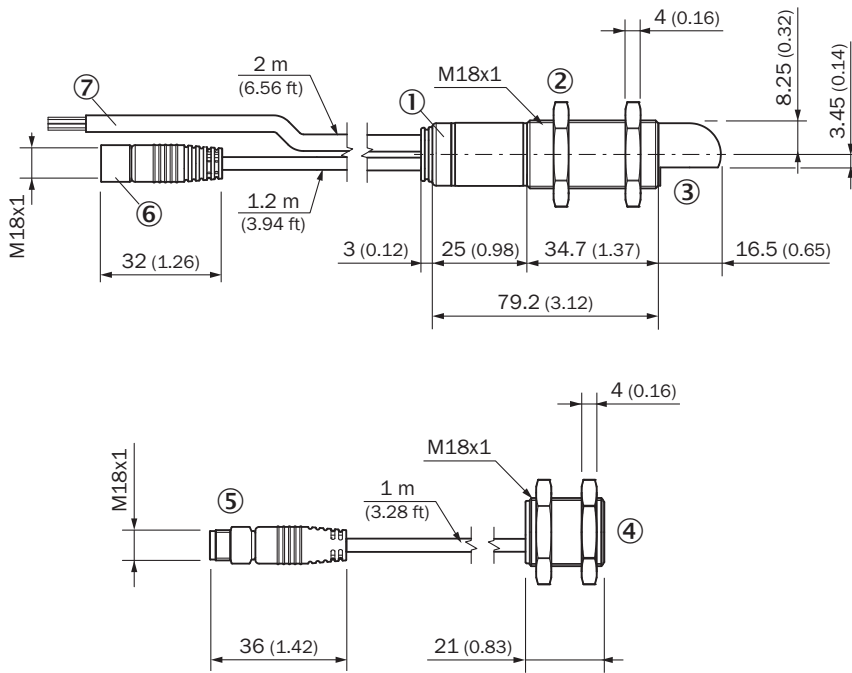

Dimensions in mm (inch)

- ① LED status indicator
- ② Fixing nuts, width 24 mm
- ③ receiver with evaluation unit
- ④ sender
- ⑤ plug M8x1, 3-pin, for connection with the receiver
- ⑥ female connector M8x1, 3-pin, for connection with the sender
- ⑦ supply voltage and controls connection cable

Pinouts, see table Technical data: Electronics

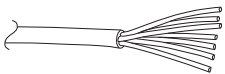

cable open end, 7-wire

connection diagram

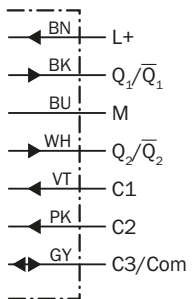

supply voltage & I/O: cable open end, 7-wire

### connection example

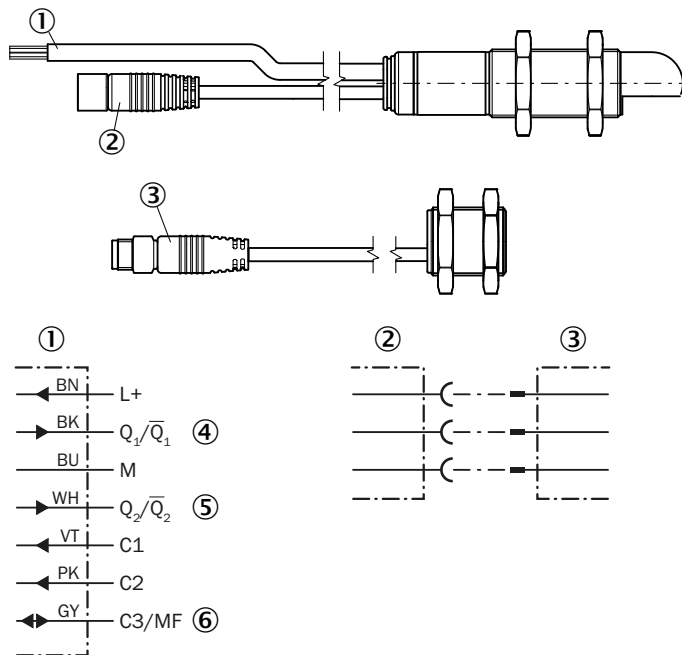

- ① connection cable for supply voltage and controls, with control inputs C1, C2, C3 and digital output Q1, Q2
- ② female connector M8x1, 3-pin, for connection with the sender
- ③ plug M8x1, 3-pin, for connection with the receiver
- ④ Switching output for "double layer"
- ⑤ Switching output for "no material / single layer"
- ⑥ Multifunctional input MF

## SICK AT A GLANCE

SICK is one of the leading manufacturers of intelligent sensors and sensor solutions for industrial applications. A unique range of products and services creates the perfect basis for controlling processes securely and efficiently, protecting individuals from accidents and preventing damage to the environment.

We have extensive experience in a wide range of industries and understand their processes and requirements. With intelligent sensors, we can deliver exactly what our customers need. In application centers in Europe, Asia and North America, system solutions are tested and optimized in accordance with customer specifications. All this makes us a reliable supplier and development partner.

Comprehensive services complete our offering: SICK LifeTime Services provide support throughout the machine life cycle and ensure safety and productivity.

For us, that is “Sensor Intelligence.”

## WORLDWIDE PRESENCE:

Contacts and other locations –[www.sick.com](http://www.sick.com)