

UD18-22CC222

UD18

FORK SENSORS

SICK
Sensor Intelligence.



Illustration may differ

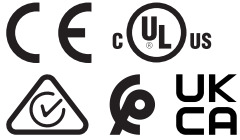

Ordering information

Type	part no.
UD18-22CC222	6058912

Other models and accessories → www.sick.com/UD18

Detailed technical data

Features

Functional principle	Ultrasonic detection principle
Housing design	Cylindrical
Dimensions (W x H x D)	18 mm x 18 mm x 79.2 mm
Installation distance	20 mm ... 60 mm, 40 mm ± 3 mm (default setting)
Fork width	60 mm (corresponds to max. mounting distance)
Blind zone	7 mm ... 7 mm (from sender and receiver)
Permissible angle deviation	± 45° perpendicular to material layer
Detectable material	Paper with grammages: 20 g/m ² ... 2,000 g/m ² Plastic sheets and foils: ≤ 0.4 mm Self-adhesive films, metal sheets: ≤ 0.3 mm Corrugated cardboard: single wall F, N and G flute sizes Washi Wafer PCB
Label detection	✓
Resolution	1 material layer
Display	2 x LED
Adjustment	Cable (Control inputs C1, C2, C3)
Additional function	3 selectable sensitivity levels Teach-in of up to 4 individual sensitivity level Sensitivity level changeover during operation Configurable via IO-Link, SOPAS and Connect+ software
Output time	2 ms, trigger mode: < 0.5 ms
Safety-related parameters	
	MTTF _D 101 years

Interfaces

Digital output	Q ₁ , Q ₂
Number	2 ¹⁾ 2 ²⁾
Type	PNP

¹⁾ Outputs Q₁ and Q₂ short-circuit protected.

²⁾ PNP: Active = V_s - (< 2 V) / Inactive = 0 V.

Function	Q ₁ : Double layer digital output, Q ₂ : No material / single layer digital output, normally closed contact in each case
Maximum output current I _A	≤ 200 mA
Control input	3 x (active ≥ 18 V, deactivated ≤ 13 V or inputs not connected)

¹⁾ Outputs Q₁ and Q₂ short-circuit protected.

²⁾ PNP: Active = V_S - (< 2 V) / Inactive = 0 V.

Electronics

Supply voltage	20 V DC ... 30 V DC ¹⁾
Ripple	± 10 %
Current consumption	50 mA ²⁾
Power consumption	≤ 1.5 W ²⁾
Initialization time	< 300 ms
Ultrasonic frequency	400 Hz
Switching frequency	250 Hz
Response time	2.5 ms
Switching output	PNP
Switching output (voltage)	PNP: HIGH = V _S - 3 V / LOW = 0 V
Output current I_{max.}	≤ 100 mA
Protection class	III ³⁾
Circuit protection	U _V connections, reverse polarity protected Output Q short-circuit protected
Connection type	
Supply voltage & I/O	Cable open end, 7-wire, 2 m
Connection type Detail	
Length of cable	2 m
Cable material	PUR
Cable diameter	4.4 mm
Conductor cross section	0.25 mm ²
Pinouts for Supply voltage & I/O	
BN	+ (L+)
BK	Q ₁ / Q ₁
BU	- (M)
WH	Q ₂ / Q ₂
VT	C1
PK	C2
GY	C3/COM

¹⁾ Limit values, reverse-polarity protected, operation in short-circuit protected network: max. 8 A.

²⁾ Without load.

³⁾ Reference voltage DC 50 V.

Mechanics

Sending axis	Angled
Thread size	M18 x 1

Housing material	Nickel-plated brass, PBT/PA
Sensing face material	Ultrasonic transducer: polyurethane foam, glass epoxy resin
Weight	Approx. 130 g

Ambient data

Ambient operating temperature	+5 °C ... +60 °C
Ambient temperature, storage	-40 °C ... +85 °C
Shock load	According to EN 60068-2-27
EMC	EN 60947-5-2 ¹⁾
Enclosure rating	IP65
UL File No.	NRKH.E191603 & NRKH7.E191603

¹⁾ The sensor complies with the electromagnetic compatibility (EMC) requirements for the industrial sector (Radio Safety Class A).

Certificates

EU declaration of conformity	✓
UK declaration of conformity	✓
ACMA declaration of conformity	✓
Moroccan declaration of conformity	✓
China RoHS	✓
cULus certificate	✓

Classifications

ECLASS 5.0	27270909
ECLASS 5.1.4	27270909
ECLASS 6.0	27270909
ECLASS 6.2	27270909
ECLASS 7.0	27270909
ECLASS 8.0	27270909
ECLASS 8.1	27270909
ECLASS 9.0	27270909
ECLASS 10.0	27270909
ECLASS 11.0	27270909
ECLASS 12.0	27270909
ETIM 5.0	EC002720
ETIM 6.0	EC002720
ETIM 7.0	EC002720
ETIM 8.0	EC002720
UNSPSC 16.0901	39121528

Dimensional drawing, sensor

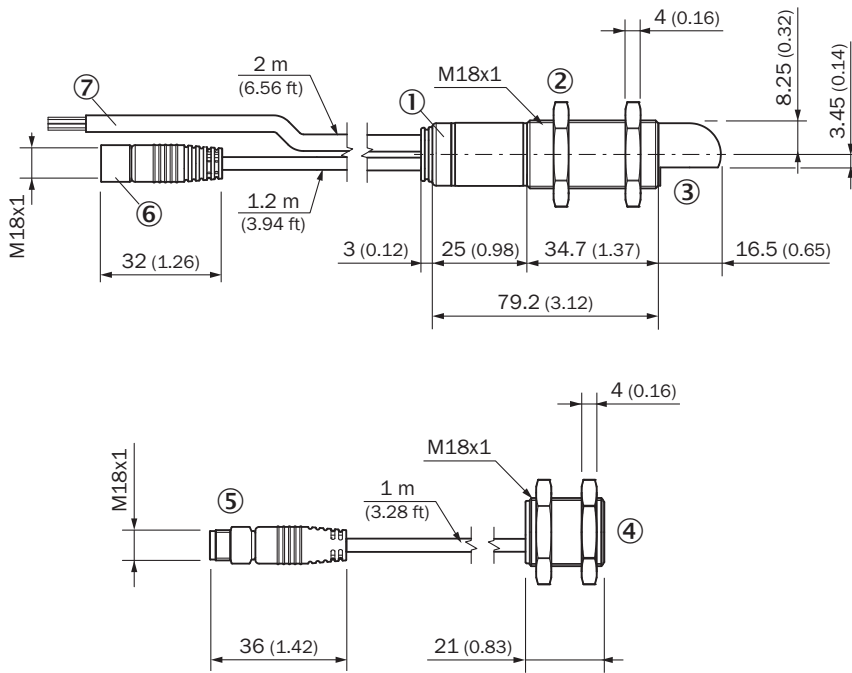

Dimensions in mm (inch)

- ① LED status indicator
- ② Fixing nuts, width 24 mm
- ③ receiver with evaluation unit
- ④ sender
- ⑤ plug M8x1, 3-pin, for connection with the receiver
- ⑥ female connector M8x1, 3-pin, for connection with the sender
- ⑦ supply voltage and controls connection cable

Pinouts, see table Technical data: Electronics

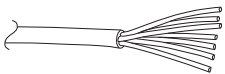

cable open end, 7-wire

connection diagram

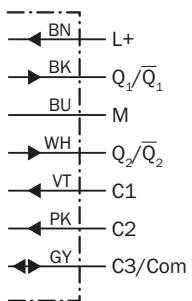

supply voltage & I/O: cable open end, 7-wire

connection example

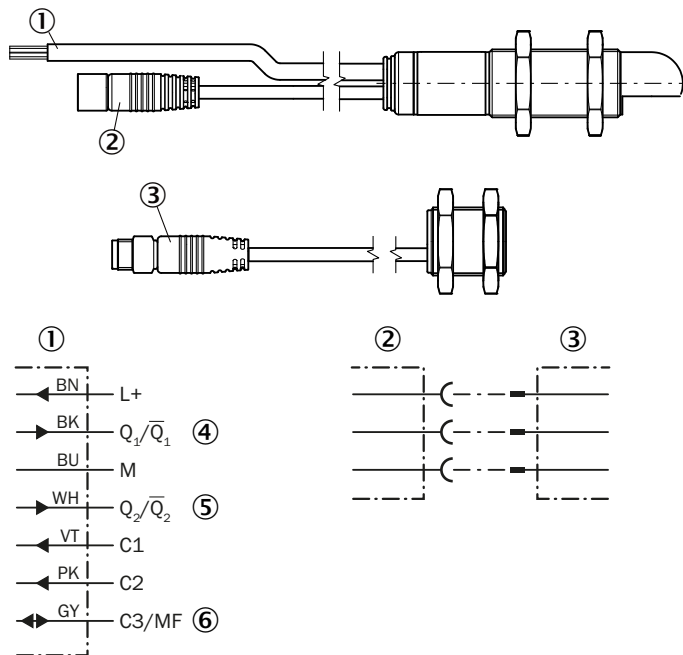

① connection cable for supply voltage and controls, with control inputs C1, C2, C3 and digital output Q1, Q2

② female connector M8x1, 3-pin, for connection with the sender

③ plug M8x1, 3-pin, for connection with the receiver

④ Switching output for “double layer”

⑤ Switching output for “no material / single layer”

⑥ Multifunctional input MF

SICK AT A GLANCE

SICK is one of the leading manufacturers of intelligent sensors and sensor solutions for industrial applications. A unique range of products and services creates the perfect basis for controlling processes securely and efficiently, protecting individuals from accidents and preventing damage to the environment.

We have extensive experience in a wide range of industries and understand their processes and requirements. With intelligent sensors, we can deliver exactly what our customers need. In application centers in Europe, Asia and North America, system solutions are tested and optimized in accordance with customer specifications. All this makes us a reliable supplier and development partner.

Comprehensive services complete our offering: SICK LifeTime Services provide support throughout the machine life cycle and ensure safety and productivity.

For us, that is “Sensor Intelligence.”

WORLDWIDE PRESENCE:

Contacts and other locations –www.sick.com