



FLG4-20025011

FLG

AUTOMATION LIGHT GRIDS

SICK
Sensor Intelligence.

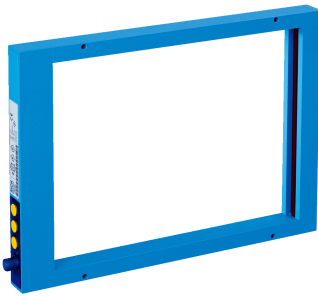

Ordering information

Type	part no.
FLG4-20025011	6049137

Other models and accessories → www.sick.com/FLG

Illustration may differ



Detailed technical data

Features

Device version	Close
Sensor principle	Sender/receiver
Minimum detectable object (MDO)	2 mm, dynamic: 4 mm 6 mm, static: 6 mm
Beam separation	4 mm
Detection height	250 mm
Output function	Light/dark switching adjustable by means of rotary switch

Mechanics/electronics

Wave length	880 nm
Supply voltage V_s	DC 18 V ... 30 V ¹⁾
Ripple	< 10 %
Output current $I_{max.}$	≤ 100 mA
Off delay	0 s ... 5 s ²⁾
Initialization time	0.3 s
Switching output	PNP ³⁾ NPN
Dimensions (W x H x D)	312 mm x 230 mm x 25 mm
Connection type	Male connector M12, 4-pin
Housing material	Aluminum, painted
Display	LED
Enclosure rating	IP65
Circuit protection	U_V connections, reverse polarity protected Output Q short-circuit protected Interference pulse suppression

¹⁾ Limit values, reverse-polarity protected, operation in short-circuit protected network: max. 8 A.

²⁾ Adjustable.

³⁾ Q / \bar{Q} .

Protection class	III
Weight	0.86 kg
Switching frequency	5,000 Hz

¹⁾ Limit values, reverse-polarity protected, operation in short-circuit protected network: max. 8 A.

²⁾ Adjustable.

³⁾ Q / Q̄.

Performance

Detection field (W x H)	250 mm x 200 mm
Response time	< 0.1 ms

Ambient data

Shock resistance	EN 60068-2-27
Vibration resistance	EN 60068-2-6
EMC	EN 60947-5-2
Ambient light immunity	Sunlight: 10,000 lx
Ambient operating temperature	0 °C ... +60 °C ¹⁾
Ambient temperature, storage	-20 °C ... +80 °C

¹⁾ In static mode: constant temperature around teaching point will be assumed.

Classifications

ECLASS 5.0	27270910
ECLASS 5.1.4	27270910
ECLASS 6.0	27270910
ECLASS 6.2	27270910
ECLASS 7.0	27270910
ECLASS 8.0	27270910
ECLASS 8.1	27270910
ECLASS 9.0	27270910
ECLASS 10.0	27270910
ECLASS 11.0	27270910
ECLASS 12.0	27270910
ETIM 5.0	EC002549
ETIM 6.0	EC002549
ETIM 7.0	EC002549
ETIM 8.0	EC002549
UNSPSC 16.0901	39121528

Certificates

EU declaration of conformity	✓
UK declaration of conformity	✓
ACMA declaration of conformity	✓
Moroccan declaration of conformity	✓
China RoHS	✓

Dimensional drawing FLGx-200xxx1x

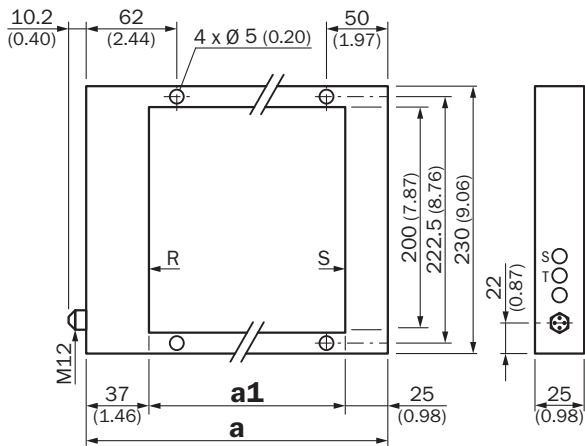

Dimensions in mm (inch)

	a	a1
FLGx-200120xx	182 (7.17)	120 (4.72)
FLGx-200180xx	242 (9.53)	180 (7.09)
FLGx-200250xx	312 (12.28)	250 (9.84)

Connection type and diagram

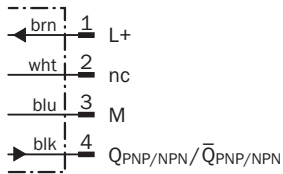
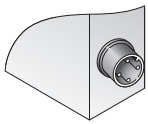

Adjustments

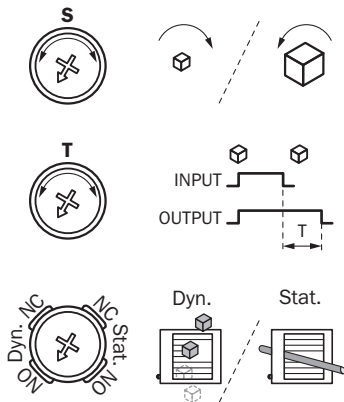

Setting the key lock

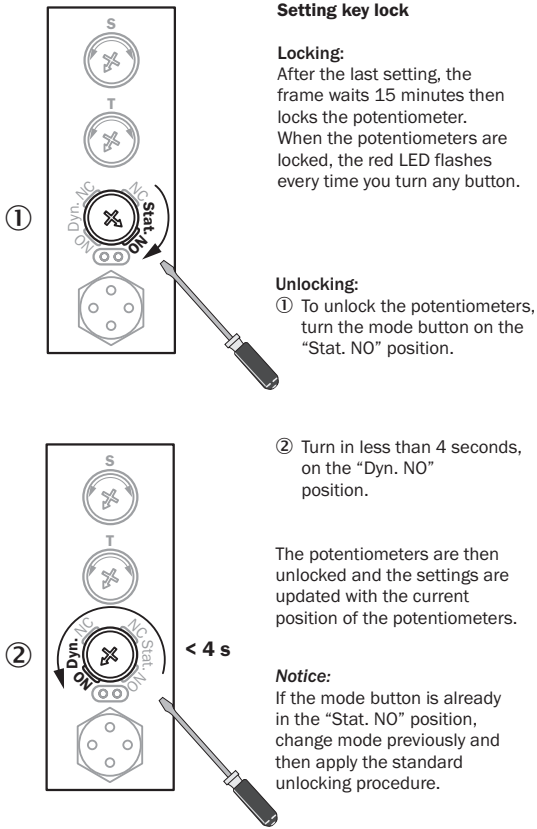

Limited detection area

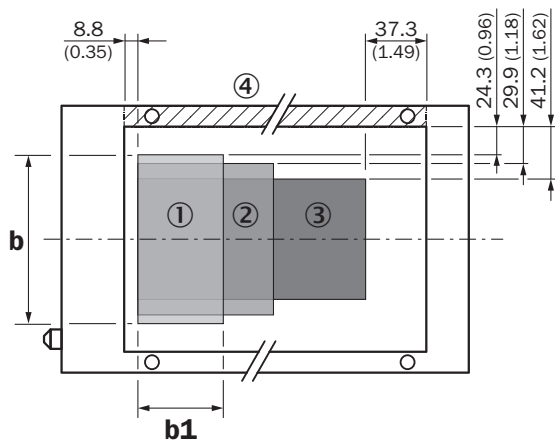

Dimensions in mm (inch)

	b	b1
① FLG2-xxx120xx	151.4 (5.96)	73.9 (2.91)
② FLG2-xxx180xx	140.2 (5.52)	133.9 (5.27)
③ FLG2-xxx250xx	117.6 (4.63)	203.9 (8.03)

All dimensions in mm (inch)

④ Side is missing in open version

Recommended accessories

Other models and accessories → www.sick.com/FLG

	Brief description	Type	part no.
connectors and cables			
	<ul style="list-style-type: none"> • Connection type head A: Female connector, M12, 4-pin, straight, A-coded • Connection type head B: Flying leads • Signal type: Sensor/actuator cable • Cable: 5 m, 4-wire, PVC • Description: Sensor/actuator cable, unshielded • Application: Uncontaminated zones, Zones with chemicals 	YF2A14-050VB3XLEAX	2096235

SICK AT A GLANCE

SICK is one of the leading manufacturers of intelligent sensors and sensor solutions for industrial applications. A unique range of products and services creates the perfect basis for controlling processes securely and efficiently, protecting individuals from accidents and preventing damage to the environment.

We have extensive experience in a wide range of industries and understand their processes and requirements. With intelligent sensors, we can deliver exactly what our customers need. In application centers in Europe, Asia and North America, system solutions are tested and optimized in accordance with customer specifications. All this makes us a reliable supplier and development partner.

Comprehensive services complete our offering: SICK LifeTime Services provide support throughout the machine life cycle and ensure safety and productivity.

For us, that is “Sensor Intelligence.”

WORLDWIDE PRESENCE:

Contacts and other locations –www.sick.com