

SICK

CAP-M18-TB

Protective caps and hoods

DEVICE PROTECTION AND CARE

SICK
Sensor Intelligence.



Ordering information

Type	part no.
CAP-M18-TB	2083431

Other models and accessories → www.sick.com/Protective_caps_and_hoods

Detailed technical data

Features

Product segment	Device protection and care
Product	Protective caps and hoods
Description	Screw-on protective cap for metric sensors. Protects the sensor from damage caused by impacts on the front.
Material	Plastic

Classifications

ECLASS 5.0	27379201
ECLASS 5.1.4	27379201
ECLASS 6.0	27379218
ECLASS 6.2	27379218
ECLASS 7.0	27379218
ECLASS 8.0	27379218
ECLASS 8.1	27379218
ECLASS 9.0	27379218
ECLASS 10.0	27371207
ECLASS 11.0	27371207
ECLASS 12.0	27371207
ETIM 5.0	EC002040
ETIM 6.0	EC002040
ETIM 7.0	EC002040
ETIM 8.0	EC002040
UNSPSC 16.0901	39121416

Dimensional drawing

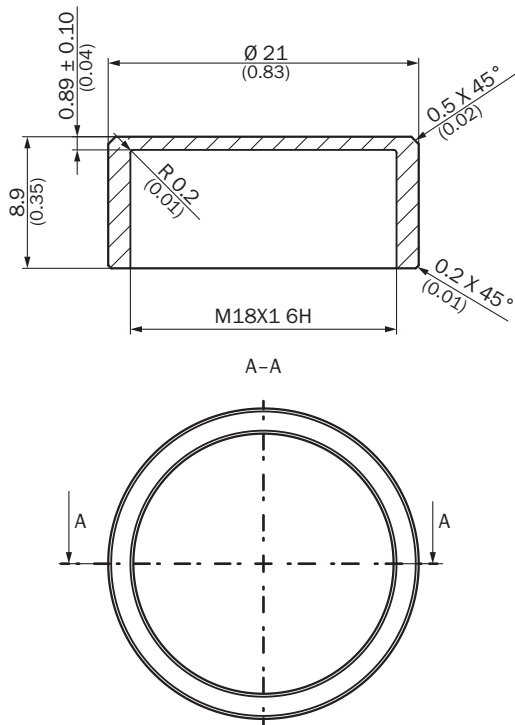

Dimensions in mm (inch)

SICK AT A GLANCE

SICK is one of the leading manufacturers of intelligent sensors and sensor solutions for industrial applications. A unique range of products and services creates the perfect basis for controlling processes securely and efficiently, protecting individuals from accidents and preventing damage to the environment.

We have extensive experience in a wide range of industries and understand their processes and requirements. With intelligent sensors, we can deliver exactly what our customers need. In application centers in Europe, Asia and North America, system solutions are tested and optimized in accordance with customer specifications. All this makes us a reliable supplier and development partner.

Comprehensive services complete our offering: SICK LifeTime Services provide support throughout the machine life cycle and ensure safety and productivity.

For us, that is “Sensor Intelligence.”

WORLDWIDE PRESENCE:

Contacts and other locations –www.sick.com