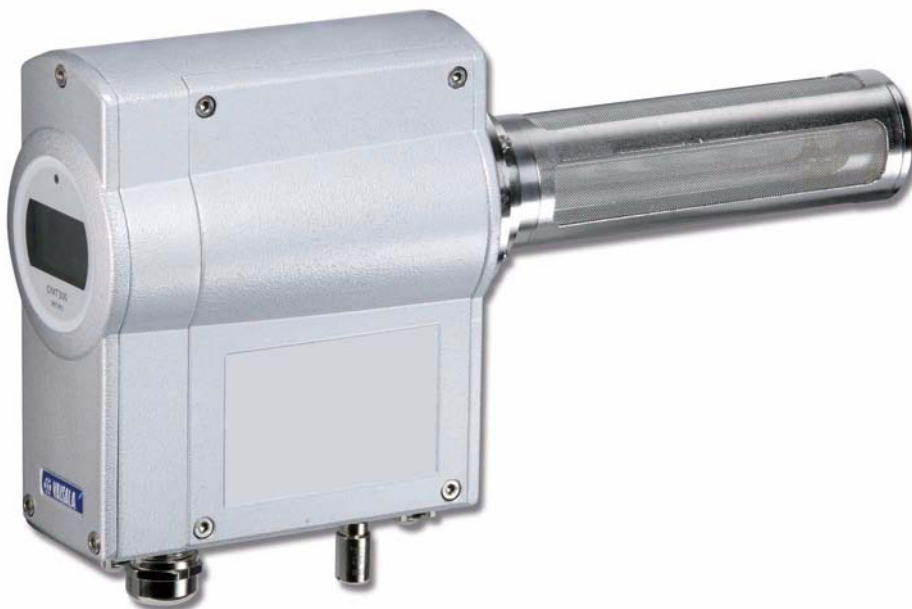


**VAISALA**

# USER'S GUIDE

## Vaisala SPECTRACAP<sup>®</sup> Oxygen Transmitter OMT364



M210862EN-A

PUBLISHED BY

Vaisala Oyj	Phone (int.):	+358 9 8949 1
P.O. Box 26	Fax:	+358 9 8949 2227
FI-00421 Helsinki		
Finland		

Visit our Internet pages at <http://www.vaisala.com/>

© Vaisala 2009

No part of this manual may be reproduced in any form or by any means, electronic or mechanical (including photocopying), nor may its contents be communicated to a third party without prior written permission of the copyright holder.

The contents are subject to change without prior notice.

Please observe that this manual does not create any legally binding obligations for Vaisala towards the customer or end user. All legally binding commitments and agreements are included exclusively in the applicable supply contract or Conditions of Sale.

---

# Table of Contents

CHAPTER 1	
<b>GENERAL INFORMATION</b>	<b>11</b>
<b>About This Manual</b>	<b>11</b>
General Safety Considerations	11
Feedback	12
<b>Product Related Safety Precautions</b>	<b>12</b>
<b>ESD Protection</b>	<b>13</b>
<b>Recycling</b>	<b>13</b>
<b>Regulatory Compliances</b>	<b>14</b>
<b>Patent Notice</b>	<b>14</b>
<b>Trademarks</b>	<b>14</b>
<b>License Agreement</b>	<b>14</b>
<b>Warranty</b>	<b>15</b>
CHAPTER 2	
<b>PRODUCT OVERVIEW</b>	<b>17</b>
<b>Introduction to OMT364</b>	<b>17</b>
<b>OMT364 in Hazardous Locations</b>	<b>17</b>
<b>OMT364 for In-Line and Sampling Cell Mounting</b>	<b>18</b>
<b>OMT364 for Ambient Gas Measurement</b>	<b>20</b>
CHAPTER 3	
<b>FUNCTIONAL DESCRIPTION</b>	<b>21</b>
<b>Measurement Principle and Sensor Technology</b>	<b>21</b>
<b>Construction of the OMT364 Probe</b>	<b>23</b>
Eye Safety	24
CHAPTER 4	
<b>INSTALLATION</b>	<b>27</b>
<b>Selecting the Location</b>	<b>27</b>
Transmitter Dimensions	28
Chemical Tolerance	28
Temperature Conditions of Installation Location	29
Powerful Light Sources Near the Oxygen Measurement Probe	29
<b>Maximum Allowed Installation Angle</b>	<b>30</b>
<b>Mounting Options</b>	<b>31</b>
Process Conditions in Regard to Mounting Options	31
Flange Mounted for In-Line Process Gas Measurement	33

---

Suitable Process Flanges .....	33
Filter Recommendation .....	33
Mounting with a Flange Adapter .....	34
Mounting with a Sampling Cell .....	35
Filter Recommendation .....	36
Mounting with a Wall Mounting Bracket .....	37
Tubing Instructions .....	38
Installation Instructions for Swagelok Tube Fittings .....	38
Sampling Cell Instructions .....	39
<b>Mounting the OMT364 for Ambient Gas Measurement</b> .....	<b>41</b>
Mounting Instructions .....	41
<b>Connections</b> .....	<b>43</b>
Signal and Power Supply Wiring .....	43
CHAPTER 5	
<b>OPERATION</b> .....	<b>47</b>
<b>Device Interfaces</b> .....	<b>47</b>
Power Supply .....	47
Keypad, Display and LEDs .....	47
Service Interface .....	48
Installing the Driver for the USB Cable .....	48
Customer Interface .....	49
Analog Output .....	49
Relay .....	50
<b>Local Interface (Keypad and Display)</b> .....	<b>50</b>
Features .....	50
Display Modes .....	50
Start-Up .....	51
Normal Operation .....	52
Error Condition .....	52
Warning .....	52
<b>Service Interface</b> .....	<b>52</b>
<b>Customer Interface</b> .....	<b>53</b>
<b>Functions</b> .....	<b>53</b>
General Instructions for Using Functions .....	53
Menu Structure .....	54
<b>Serial Commands</b> .....	<b>58</b>
List of Serial Commands .....	59
<b>Outputting Measurement Results</b> .....	<b>60</b>
Start Continuous Output Command (R) .....	60
Stop Continuous Output Command (S) .....	61
Show/Set Continuous Output Interval Command (INTV) .....	61
Send Measurement Results Command (SEND) .....	62
Show/Set Serial Communications Mode Command (SMODE) .....	62
Show/Set Serial Communications Mode for Line 2 Command (SMODE2) .....	63
Show/Set Serial Communications Settings Command (SERI) .....	63

---

Show/Set Serial Communication Settings for Line 2 Command (SERI2) .....	64
Show Serial Line 1 Status Command (SCI1) .....	65
Show Serial Line 2 Status Command (SCI2) .....	65
Show Measurement Status Command (MEA) .....	66
Oxygen Statistics Display Function .....	66
Temperature Statistics Display Function .....	67
<b>Formatting Measurement Results .....</b>	<b>67</b>
Set Output Format Command (FORM) .....	67
Show/Set Date Command (DATE) .....	69
Show/Set Time Command (TIME) .....	70
<b>Networking Operation .....</b>	<b>70</b>
Show/Set Device Address Command (ADDR) .....	70
Open Communications Line Command (OPEN) .....	71
Close Serial Line in Poll Mode Command (CLOSE) .....	71
Set Echoing Mode Command (ECHO) .....	72
<b>Accessing Service Level Commands .....</b>	<b>73</b>
Issue Password Command (PASS) .....	73
Issue Password Function (Pas) .....	73
<b>Analog Output Calibration .....</b>	<b>74</b>
Calibrate Analog Output Command (ICAL) .....	74
<b>Analog Output Scaling and Settings .....</b>	<b>75</b>
Scale Analog Output Function (Ascl) .....	75
Show/Set Output Parameters Command (OUT_PARAMS) .....	75
<b>Analog Output Testing .....</b>	<b>76</b>
Set Test Current to Analog Output Command (ITEST) .....	76
Test Analog Output Function (Aou) .....	77
<b>Relay Operation .....</b>	<b>78</b>
Show/Set Relay Operating Mode Command (RELAY_MODE) .....	78
Show/Set Relay Trigger Points Command (RSEL) .....	78
Test Alarm Relay Function (Ala) .....	79
<b>Device Information and Other General Commands .....</b>	<b>79</b>
Show Information about the Device Command (?) .....	79
Show Information about the Device Overriding POLL Mode Command (??) .....	80
Show Measuring Parameters Command (CALCS) .....	81
Show Calibration Information (CINFO) .....	81
Show Display Board Status Command (DB) .....	82
List Commands Command (HELP) .....	82
Show Laser Temperature Controller Status Command (LTC) .....	83
Show Output Status Command (OUT) .....	83
Show All Modifiable Parameter Values (PARAM) .....	84
Measure Signal Level Command (SIL) .....	84
Signal Level Display Function (Sil) .....	85
Show Statistical Information Command (STATS) .....	85
Show Status of Subfunctions Command (STATUS) .....	86
Show Product Name and Software Version Command (VERS) .....	87

---

<b>Memory Handling</b> .....	<b>87</b>
Save Parameters Command (SAVE) .....	87
<b>Resetting the Transmitter</b> .....	<b>88</b>
Reset Command (RESET) .....	88
Reset Function (Off) .....	88

CHAPTER 6

**SETTING ENVIRONMENTAL PARAMETERS** ..... **89**

<b>Environmental Parameter Compensations</b> .....	<b>89</b>
Operating Temperature .....	90
Operating Pressure .....	90
Show/Set Pressure for Compensation Command (PRES).....	92
Set Pressure for Compensation Command (XPRES) .	93
Set (Average) Process Pressure Function (App).....	93
Background Gas Effects .....	94
General Information About Background Gas Effects . .	94
Water Content of Background Gas .....	95
Set Water Content for Compensation Command (H2O)	97
Set (Average) Water Content Function (H2O).....	98
CO2 Concentration of Background Gas.....	98
Set Carbon Dioxide Content for Compensation Command (CO2) .....	98
Set (Average) Carbon Dioxide Content Function (CO2)	99
Setting Several/All Environmental Parameters with Single Command (ENV) .....	100

CHAPTER 7

**CALIBRATION AND ADJUSTMENT (IN-LINE AND SAMPLING CELL  
VERSIONS OF OMT364)** ..... **101**

<b>Hardware Arrangements for Calibration and Adjustment</b> .....	<b>102</b>
Getting Started .....	102
Gas Feed Setup for Calibration and Adjustment .....	102
Using Ambient Air .....	102
Using Bottled Gas and Calibration Chamber.....	103
Setup.....	103
Calibration or Adjustment in Process.....	103
Connections and Systems .....	104
Preparations for Adjustment .....	104
Connecting the Gas .....	104
Adjusting Gas Flow.....	105
Information on Calibration Gases.....	106
<b>Calibration</b> .....	<b>107</b>
Using Ambient Air .....	107
Using Calibration Gases .....	108
<b>Calibration Procedures</b> .....	<b>108</b>
Lock Outputs for Calibration Command (ADJUST) .....	108
Calibration Check Function (Cal.C) .....	108
<b>Adjustment</b> .....	<b>109</b>

Possible Adjustments .....	110
One-Point Adjustment Using Serial Line .....	110
One-Point Adjustment Command (COXY1) and Procedure Using Serial Line .....	110
One-Point Adjustment Using Local Interface .....	112
One-Point Adjustment Function (CAL1).....	112
One-Point Adjustment Procedure Using Local Interface .....	113
Two-Point Adjustment Using Serial Line .....	114
Two-Point Adjustment Command (COXY2) and Procedure Using Serial Line .....	114
Two-Point Adjustment Using Local Interface .....	117
Two-Point Adjustment Function (CAL2).....	117
Two-Point Adjustment Procedure Using Local Interface .....	117
Restoring Factory Calibration .....	119
Restore Factory Calibration Command (FCRESTORE) .....	119
Restore Factory Calibration Function (Fac).....	119

CHAPTER 8

**CALIBRATION AND ADJUSTMENT (AMBIENT GAS MEASUREMENT  
VERSION OF OMT364) .....**

<b>Hardware Arrangements for Calibration and Adjustment .....</b>	<b>122</b>
Getting Started .....	122
Gas Feed Setup for Calibration and Adjustment .....	123
Using Ambient Air .....	123
Using Bottled Calibration Adjustment Gas.....	123
<b>Calibration .....</b>	<b>124</b>
Using Ambient Air .....	124
Using Calibration Gas .....	125
Information on Calibration Gases .....	126
<b>Calibration Procedures .....</b>	<b>127</b>
Lock Outputs for Calibration Command (ADJUST) .....	127
Calibration Check Function (Cal.C) .....	127
<b>Adjustment .....</b>	<b>128</b>
Possible Adjustments for Ambient Measurement Version	129
One-Point Adjustment Using Serial Line .....	129
One-Point Adjustment Command (COXY1) and Procedure Using Serial Line .....	129
One-Point Adjustment Using Local Interface .....	131
One-Point Adjustment Function (CAL1).....	131
One-Point Adjustment Procedure Using Local Interface .....	132
Restoring Factory Calibration .....	133
Restore Factory Calibration Command (FCRESTORE) .....	133
Restore Factory Calibration Function (Fac).....	134

---

CHAPTER 9	
<b>MAINTENANCE</b>	<b>135</b>
<b>Field Maintenance</b>	<b>135</b>
Cleaning the Optics	135
Using Solvents to Clean the Optics	136
Cleaning the Mirror	136
Cleaning the Lens	137
<b>Replacing Consumables</b>	<b>138</b>
OMT364 Filters	138
Filter Change	138
Cleaning and Changing the Stainless Steel Mesh	
Filter	138
Changing the PTFE Filter	139
CHAPTER 10	
<b>TROUBLESHOOTING</b>	<b>141</b>
<b>Operation Errors</b>	<b>141</b>
Self-Test	141
Error Detection During Operation	142
Error Control and Error Categories	143
Fatal Errors	144
Nonfatal Errors	144
Warnings	145
Emergency Shutdown State	145
Show Error Control Status (ERR)	145
Show Error Log (ERRL)	146
Show Detected Errors (ERRS)	146
Show Error Table (ERRT)	146
Error Display	147
Error Table	148
<b>Technical Support</b>	<b>149</b>
<b>Return Instructions</b>	<b>149</b>
<b>Vaisala Service Centers</b>	<b>149</b>
CHAPTER 11	
<b>TECHNICAL DATA</b>	<b>151</b>
<b>Specifications</b>	<b>151</b>
<b>Spare Parts and Accessories</b>	<b>154</b>
APPENDIX A	
<b>FLANGE PREPARATION INSTRUCTIONS</b>	<b>155</b>
APPENDIX B	
<b>HUMIDITY CONVERSION TABLE</b>	<b>157</b>
APPENDIX C	
<b>CONTROL DRAWINGS AND CERTIFICATES</b>	<b>159</b>

---

## List of Figures

Figure 1	Flange Mounted OMT364	19
Figure 2	OMT364 with Sampling Cell	19
Figure 3	OMT364 for Ambient Gas Measurement	20
Figure 4	O2 Absorption Spectrum Around the 760 nm Near Infrared Region	22
Figure 5	Adjacent O2 Absorption Lines and Laser Emission Peak	22
Figure 6	Schematic of Probe Design	23
Figure 7	OMT364 Laser Eye Safety	24
Figure 8	OMT364 Dimensions	28
Figure 9	Installation Angle Limitations in High Humidities	31
Figure 10	OMT364 Transmitter with Flange Adapter	33
Figure 11	Dimensions of OMT 364 Flange Mounted	35
Figure 12	OMT364 Transmitter with Sampling Cell	36
Figure 13	Sample Gas Treatment System	37
Figure 14	Swagelok Tube Fitting Instructions	39
Figure 15	Detaching the Sampling Cell	40
Figure 16	Dimensions, OMT364 with Sampling Cell	40
Figure 17	OMT364 for Ambient Gas Measurement with Wall Mounting Setup	41
Figure 18	OMT364 Wall Mounted	42
Figure 19	Dimensions and Drilling Holes, Wall Mounting Bracket (Right) and Flange Adapter (Left)	43
Figure 20	Connections/Local Interface Layout	44
Figure 21	OMT364 Display Layout	50
Figure 22	Effect of Process Pressure Compensation	91
Figure 23	Attaching OMT364 Probe into Calibration Chamber	103
Figure 24	Flow Rate vs. Pressure, Back Pressure Valve Swagelok SS-CHSM2-KZ-25	106
Figure 25	Oxygen Readings in Relative Humidity	107
Figure 26	Attaching OMT364 Probe into Sample Cell	124
Figure 27	Oxygen Readings in Alternating Humidity	125
Figure 28	Calibration Gas O2 Concentration Readings for Ambient Gas Measurement Version of OMT364	126
Figure 29	Location of Mirror in Oxygen Measurement Probe	136
Figure 30	Location of Lens in Oxygen Measurement Probe	137
Figure 31	Stainless Steel Mesh and PTFE Filters	138
Figure 32	OMT364 Control Drawing, FM	160
Figure 33	US Certificate - Page 1	161
Figure 34	US Certificate - Page 2	162
Figure 35	Canadian Certificate - Page 1	163
Figure 36	Canadian Certificate - Page 2	164



---

## List of Tables

Table 1	Process Conditions and Mounting Options . . . . .	32
Table 2	Meaning of the Command Line Elements . . . . .	58
Table 3	OMT364 Default Serial Communication Settings. . . . .	58
Table 4	List of Serial Commands without Password. . . . .	59
Table 5	List of Additional Serial Commands with Password Given. . . . .	59
Table 6	Format String Abbreviations and Quantities . . . . .	68
Table 7	Format String Modifiers . . . . .	68
Table 8	Conversion Table from T and RH to Absolute Humidity and the Effect of Humidity on Transmitter Reading . . . . .	96
Table 9	Actions When Fatal Error Has Been Detected. . . . .	144
Table 10	Actions When Nonfatal Error Has Been Detected . . . . .	144
Table 11	Actions When Warning Has Been Detected . . . . .	145
Table 12	Emergency Shutdown Actions . . . . .	145
Table 13	Error Table . . . . .	148
Table 14	Performance . . . . .	151
Table 15	Background Gas Effect . . . . .	152
Table 16	Operating Environment . . . . .	152
Table 17	Inputs and Outputs. . . . .	152
Table 18	Approvals and Fulfilled Standards . . . . .	153
Table 19	Dimensions and Mechanics. . . . .	153
Table 20	Available Spare Parts and Accessories . . . . .	154



# CHAPTER 1

## GENERAL INFORMATION

### About This Manual

This manual provides information for installing, operating, and maintaining Vaisala SPECTRACAP<sup>®</sup> Oxygen Transmitter OMT364.

### General Safety Considerations

Throughout the manual, important safety considerations are highlighted as follows:

**WARNING**

Warning alerts you to a serious hazard. If you do not read and follow instructions very carefully at this point, there is a risk of injury or even death.

**CAUTION**

Caution warns you of a potential hazard. If you do not read and follow instructions carefully at this point, the product could be damaged or important data could be lost.

**NOTE**

Note highlights important information on using the product.

## Feedback

Vaisala Customer Documentation Team welcomes your comments and suggestions on the quality and usefulness of this publication. If you find errors or have other suggestions for improvement, please indicate the chapter, section, and page number. You can send comments to us by e-mail: [manuals@vaisala.com](mailto:manuals@vaisala.com).

## Product Related Safety Precautions

The Vaisala SPECTRACAP® Oxygen Transmitter OMT364 delivered to you has been tested for safety and approved as shipped from the factory. The wetted components of the transmitter are oxygen compatible, and have been cleaned at the factory to ensure that they can be safely placed in 100% oxygen. Only oxygen compatible lubricant (Krytox 240 AC) has been used in the assembly.

Note the following precautions:

**WARNING**

Ground the product, and verify outdoor installation grounding periodically to minimize shock hazard.

**CAUTION**

Do not modify the unit. Improper modification can damage the product or lead to malfunction.

**CAUTION**

OMT364 is a Class 1 laser product.

Normal handling and operation of the device is eye-safe, because laser radiation is collimated and maintained inside the probe, as is schematically shown in [Figure 7 on page 24](#). No laser radiation is emitted outside the probe. Avoid placing reflective surfaces (tools, etc.) directly into the probe when the transmitter is in operation, since this might cause reflection of laser radiation outside the probe.

## ESD Protection

Electrostatic Discharge (ESD) can cause immediate or latent damage to electronic circuits. Vaisala products are adequately protected against ESD for their intended use. However, it is possible to damage the product by delivering electrostatic discharges when touching, removing, or inserting any objects inside the equipment housing.

To make sure you are not delivering high static voltages yourself:

- Handle ESD sensitive components on a properly grounded and protected ESD workbench. When this is not possible, ground yourself with a wrist strap and a resistive connection cord to the equipment chassis before touching the boards. When neither of the above is possible, at least touch a conductive part of the equipment chassis with your other hand before touching the boards.
- Always hold the boards by the edges and avoid touching the component contacts.

## Recycling



Recycle all applicable material.



Dispose of batteries and the unit according to statutory regulations.  
Do not dispose of with regular household refuse.

## Regulatory Compliances

OMT364 Oxygen Transmitter is classified as Class 1 laser device in accordance with IEC 60825-1. CDRH accession number: 07R0485-000.



OMT364 Oxygen Transmitter is approved for Class I, Division 2, Groups A, B, C and D. Sensor for Class I, Division 1 and 2, Groups A, B, C and D hazardous indoor and outdoor locations with an enclosure rating IP66. Temperature class T4.

## Patent Notice

The OMT364 Oxygen Transmitter is protected by the following patents and their corresponding national rights:

Finnish patent 117808, U.S. patent 7405827.

## Trademarks

Vaisala SPECTRACAP<sup>®</sup> is a registered trademark of Vaisala Oyj. Kalrez<sup>®</sup> and Krytox<sup>®</sup> are registered trademarks of DuPont.

## License Agreement

All rights to any software are held by Vaisala or third parties. The customer is allowed to use the software only to the extent that is provided by the applicable supply contract or Software License Agreement.

## Warranty

For certain products Vaisala normally gives a limited one-year warranty. Please observe that any such warranty may not be valid in case of damage due to normal wear and tear, exceptional operating conditions, negligent handling or installation, or unauthorized modifications. Please see the applicable supply contract or Conditions of Sale for details of the warranty for each product.



## CHAPTER 2

# PRODUCT OVERVIEW

## Introduction to OMT364

The following sections provide a short overview of the Vaisala SPECTRACAP<sup>®</sup> Oxygen Transmitter OMT364 and describe the three different versions of the product.

The OMT364 is an optical device for measuring oxygen concentration in gases. The instrument consists of a measurement probe attached to an electronics enclosure. Typical applications of OMT364 include inert gas blanketing and pharmaceutical processes in demanding environments, where hazardous gas is present. The nonincendive transmitter can be located in Class I, Division 2 and the encapsulated probe in Class I, Division 1.

## OMT364 in Hazardous Locations

Because of the structure of the transmitter, pay special attention to selecting the location where the transmitter will be installed and take into consideration the Division separation, see [Figure 1 on page 19](#), [Figure 2 on page 19](#) and [Figure 3 on page 20](#). Follow the instructions for cabling given in the control drawing, see [Appendix A, Flange Preparation Instructions, on page 155](#).

**CAUTION**

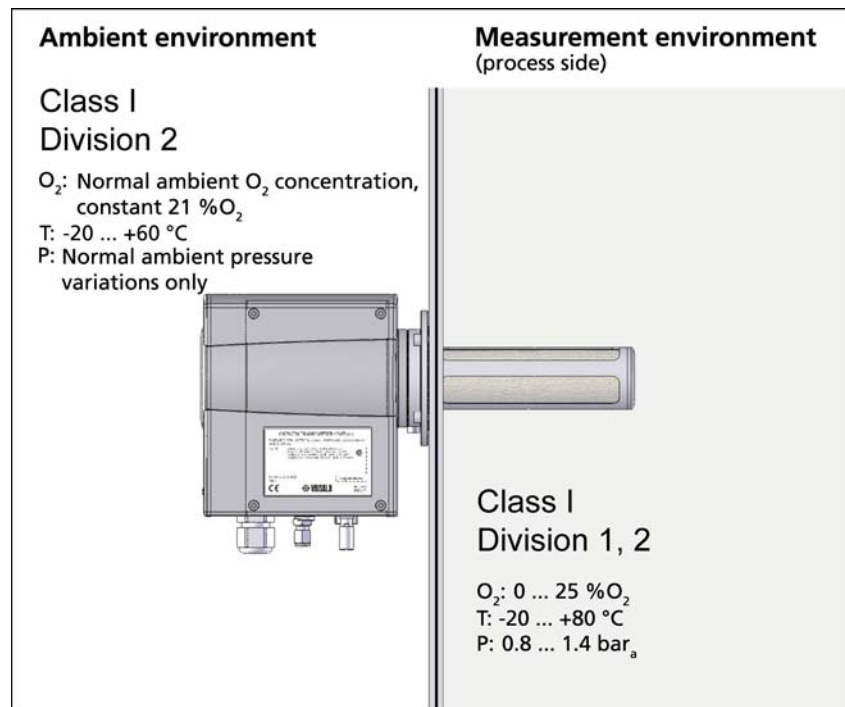
Samples in excess of 25% O<sub>2</sub> should not be measured (or appear) in hazardous areas!

## OMT364 for In-Line and Sampling Cell Mounting

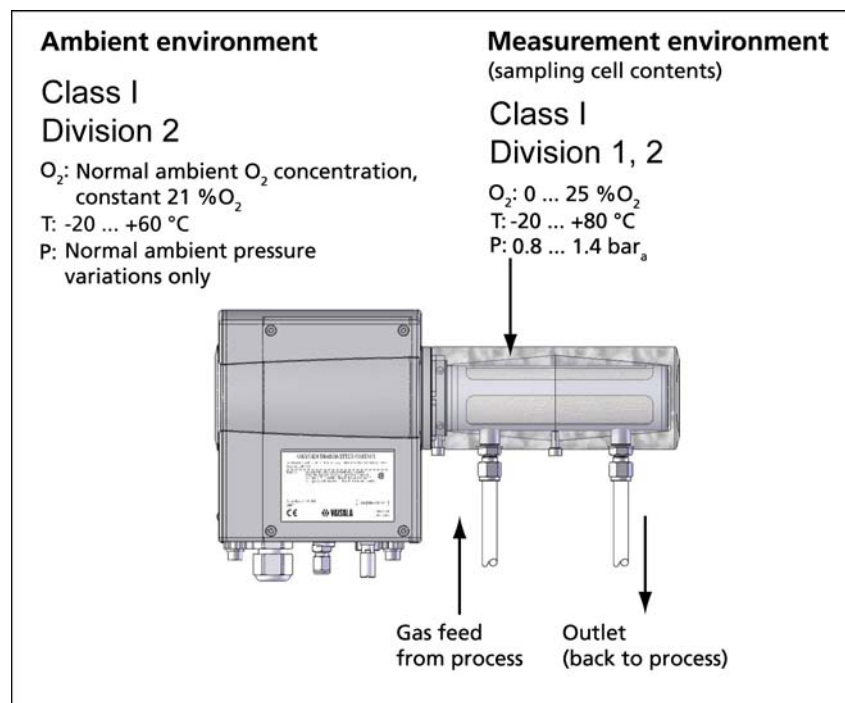
In processes with moderate temperatures (up to 80 °C) and limited pressures (0.8 ... 1.4 bar<sub>a</sub>), OMT364 can be installed directly into the process (in-line mounting) using a mounting flange, whereas in processes with high temperatures (> 80 °C), high pressures (> 1.4 bar<sub>a</sub>) or extremely difficult mechanical conditions (viscous liquids or slurries, adhesive materials) an extractive measurement can be made by feeding a sample of gas into an optional sampling cell.

In in-line and sampling cell configurations the OMT364 transmitter measures process and sampled O<sub>2</sub> concentrations of 0 ... 25 %O<sub>2</sub>. With these configurations, it is assumed that the transmitter housing is mounted in an environment that has only normal pressure variations and O<sub>2</sub> concentration of normal ambient air, approximately 21 %O<sub>2</sub>. The environmental conditions of the electronics housing affect the O<sub>2</sub> measurement, because O<sub>2</sub> absorption of normal surrounding air inside the enclosure is used for realizing certain internal functions of the measurement.

[Figure 1 on page 19](#) and [Figure 2 on page 19](#) contain the main specifications for the measurement environment and mounting the OMT364.

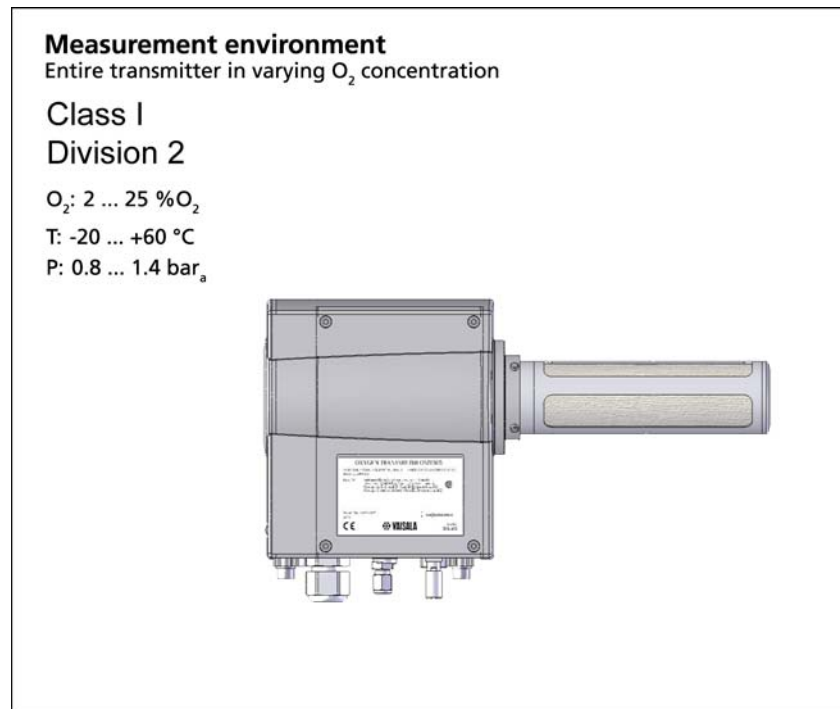


**Figure 1 Flange Mounted OMT364**



**Figure 2 OMT364 with Sampling Cell**

## OMT364 for Ambient Gas Measurement



**Figure 3** OMT364 for Ambient Gas Measurement

Ambient oxygen concentration measurement, for example in oxygen deficiency monitoring, requires a special version of OMT364. Please observe that sections of this User's Guide covering the version for ambient gas measurement are applicable only to customers who have ordered this specific version of the transmitter.

With the ambient environment configuration it is assumed that the **entire transmitter** (both measurement probe and transmitter housing) is installed in an environment of changing O<sub>2</sub> concentration. See [Figure 3 on page 20](#) for an installation environment example.

The ambient environment configuration of OMT364 measures ambient oxygen concentrations of 2 ... 25 %O<sub>2</sub>, that is, the main difference between this version in comparison with the other two is that the measurement range does not go all the way down to zero percent O<sub>2</sub>. There are also differences in operating temperature ranges between these configurations, see [Figures 1-3 and Table 16 on page 152](#).

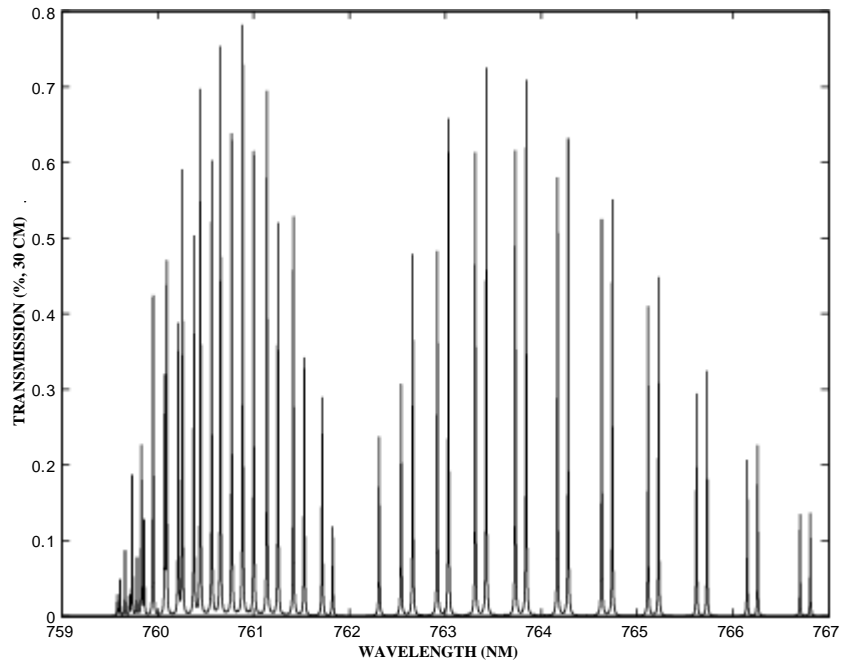
To facilitate easy installation on walls, OMT364 for ambient gas measurement is available with a wall mounting kit.

## CHAPTER 3

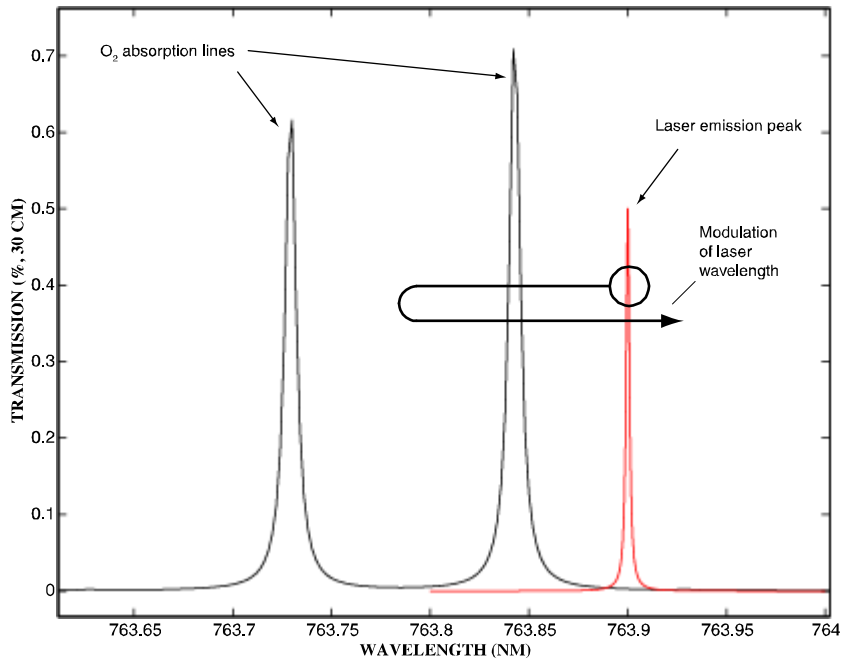
# FUNCTIONAL DESCRIPTION

## Measurement Principle and Sensor Technology

The operation of the SPECTRACAP<sup>®</sup> sensor used in OMT364 is based on Tunable Diode Laser Absorption Spectroscopy (TDLAS) method. In this technology the gas concentration is sensed by measuring the attenuation of a beam of laser light from a tunable diode laser source in the sample gas. For oxygen sensing the laser wavelength is selected to match with one of the characteristic absorption lines of oxygen in the wavelength range of around 760 nm (0.76  $\mu\text{m}$ ), in the near infrared (NIR) region of the electromagnetic spectrum. In the measurement the diode laser wavelength is continuously modulated to scan across one of the oxygen absorption lines to generate a periodic signal from a photodetector, the amplitude of which is proportional to the amount of oxygen on the path of the laser beam. [Figure 4 on page 22](#) illustrates the oxygen absorption spectrum and [Figure 5 on page 22](#) the modulation of the laser wavelength.



**Figure 4** **O<sub>2</sub> Absorption Spectrum Around the 760 nm Near Infrared Region**

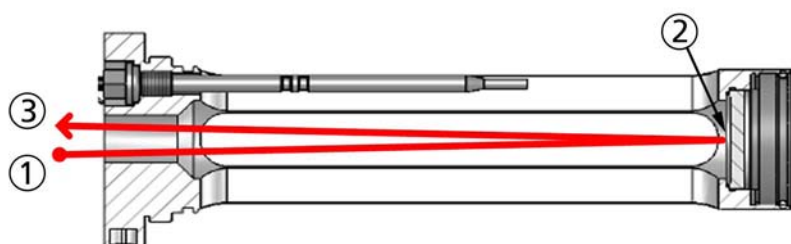


**Figure 5** **Adjacent O<sub>2</sub> Absorption Lines and Laser Emission Peak**

Characteristic of the SPECTRACAP<sup>®</sup> sensor is its inherently good stability which is obtained due to the continuous reference measurement built in the measurement algorithm. Furthermore the technology is fast since no chemical reactions or gas diffusion in sensor materials are involved - in practice the response time is dictated only by the gas exchange into the sensor volume and the signal processing time of the electronics. Furthermore, since the absorption lines of gases are very narrow and unique by nature, there is no direct cross sensitivity to other gases in the measurement.

## Construction of the OMT364 Probe

The SPECTRACAP<sup>®</sup> sensor of the OMT364 has been built into a compact and robust probe for direct insertion into the measurement location. In the probe the diode laser light source and the photodetector measuring the light have been placed behind a protective window, and the light is directed onto the photodetector using a focusing mirror at the far end of the probe. [Figure 6 on page 23](#) illustrates the probe design and how the beam of light goes once back and forth inside the probe.



**Figure 6** Schematic of Probe Design

The following numbers refer to [Figure 6 on page 23](#):

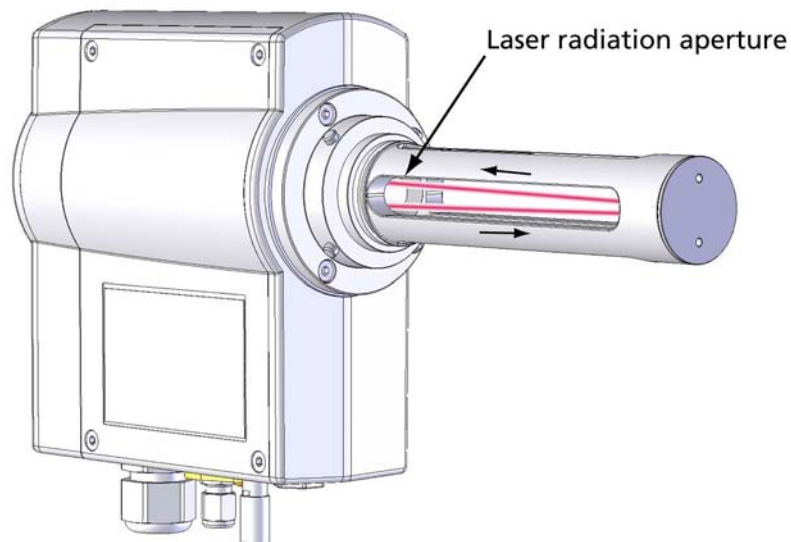
- 1 = Light source
- 2 = Mirror
- 3 = Light detector

The probe is constructed from AISI 316 stainless steel for good resistance to aggressive chemicals and demanding environments. Other sample wetted materials are the thin film coating of the optical surfaces ( $\text{MgF}_2$  on the lens, SiN on the mirror), and the Kalrez<sup>®</sup> Spectrum 6375

O-ring. The probe design incorporates also an encapsulated Pt1000 temperature sensor for making an on-line temperature compensation to the measurement, and a heating resistor heats the protective window to prevent condensation. The probe is also equipped with a stainless steel mesh filter (additional porous PTFE filter available as an option) to prevent dust or particles from entering inside the probe. If this should nevertheless happen the algorithm used with the SPECTRACAP<sup>®</sup> sensor has been designed to minimize the effects of light obstruction, and even to issue a maintenance warning signal informing of excessive light loss in the sensor well before the measurement quality is affected.

## Eye Safety

The OMT364 is eye-safe. Laser radiation in OMT364 is emitted through the laser radiation aperture, as shown in [Figure 7 on page 24](#). No laser radiation is emitted outside the probe, and in normal conditions it is not possible to look straight into the laser radiation aperture and place the eye in the path of the laser beam. Therefore normal handling and operation of OMT364 is eye-safe. Do not place reflective surfaces (tools, etc.) directly into the probe, since this might cause reflection of laser radiation outside the probe.



**Figure 7** OMT364 Laser Eye Safety

**NOTE**

Optical radiation of SPECTRACAP<sup>®</sup> cannot ignite any hazardous gas when operating pressure is between 0.8 ... 1.4 bar.

**CAUTION**

Do not use OMT364 in situations where process pressure can even sporadically exceed 1.4 bar.

The Minimum Ignition Energy is inversely proportional to the pressure of the gas or vapour. In practise this means, that the level of energy (optical radiation) needed to cause an ignition is substantially reduced as pressure increases.



## CHAPTER 4

# INSTALLATION

### Selecting the Location

When selecting the installation location for your version of the OMT364, remember to consider the division separation. If desired, the entire transmitter can be installed in a **Class I, Division 2** environment as shown in [Figure 3 on page 20](#).

By using the mounting flange or the sampling cell, the measurement probe can be placed in a **Class I, Division 1** environment, while the rest of the transmitter remains in a **Class I, Division 2** environment. Refer to [Figure 1 on page 19](#) and [Figure 2 on page 19](#).

The main advantage of OMT364 is its low sensitivity to sample gas conditions, meaning that the requirements for costly and complicated sample conditioning systems are minimal. In many applications OMT364 can be installed directly into the process using a mounting flange. There is no need for sampling and sample conditioning equipment. This type of setup also provides a real-time measurement with no sampling or sample switching delays.

## Transmitter Dimensions

Figure 8 on page 28 presents the dimensions of the OMT364 transmitter in mm/inch.

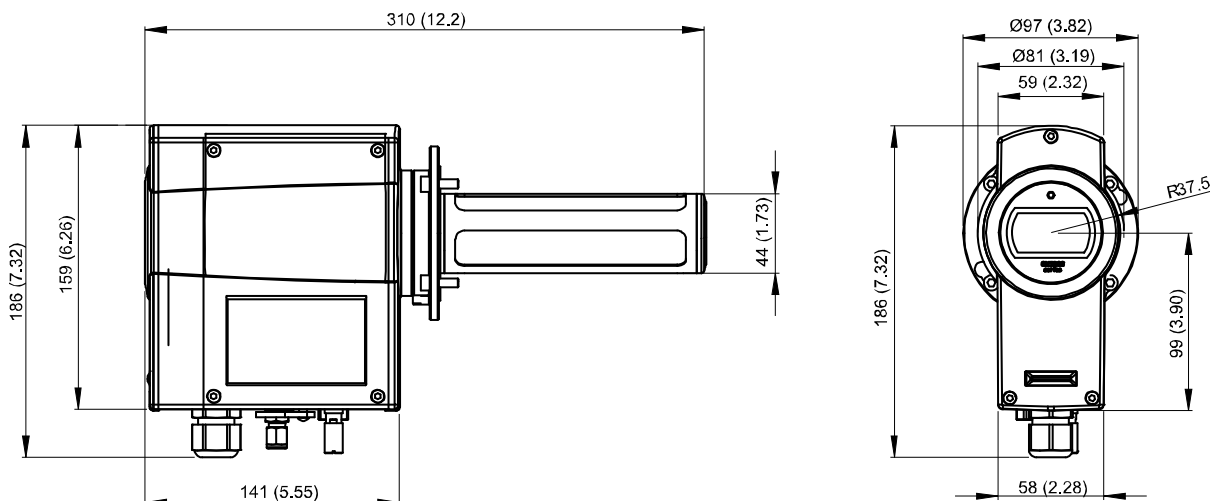


Figure 8 OMT364 Dimensions

## Chemical Tolerance

The OMT364 transmitter contains several O-ring sealings. The sealings are made of Kalrez<sup>®</sup> Spectrum 6375 (perfluoroelastomer with a fluorinated backbone). Kalrez sealings have an excellent tolerance for aggressive solvents and chemicals, for example:

- Alcohols (butanol, ethanol, isopropanol, methanol)
- Aromatic hydrocarbons (benzene, toluene, xylene)
- Esters (ethyl acetate)
- Ethers (diethyl ether)
- Ketones (acetone)

## Temperature Conditions of Installation Location

The probe design of OMT364 incorporates a temperature sensor for making an on-line temperature compensation to the oxygen measurement. Therefore finding a suitable site for OMT364 is important for getting representative temperature measurements.

In spite of the low sensitivity to sample gas conditions when installing OMT364 directly into the process, it is still important to take into account the differences between the process gas temperature and the ambient temperature. In this type of installation, the integrated temperature probe of OMT364 is located inside the process while the transmitter electronics enclosure remains outside the process. For operating temperature range of the transmitter, see [Table 16 on page 152](#).

The temperature probe and transmitter enclosure are in contact with each other via some heat transferring components. Thus, ambient temperature affects the reading of the temperature probe. This causes measurement error, because the temperature reading used in the compensations will be slightly different compared to the actual process gas temperature.

A location in which the ambient temperature of the transmitter enclosure is as close to the process temperature as possible minimizes this effect and vice versa - the smaller the temperature gradient from the process to the ambient is, the smaller the error will be. Please see [Table 14 on page 151](#) for measurement specifications.

## Powerful Light Sources Near the Oxygen Measurement Probe

It is not recommended to install the transmitter in locations where there is an exceptionally powerful light source in close proximity to the measurement probe (this only concerns the probe, the transmitter housing is not affected by light sources).

A powerful light source can interfere with the operation of the light detector. The interfering effect of a light source depends on the filter used on the measurement probe and how severely the light is shining into the measurement probe. The interfering effect is at its worst if no

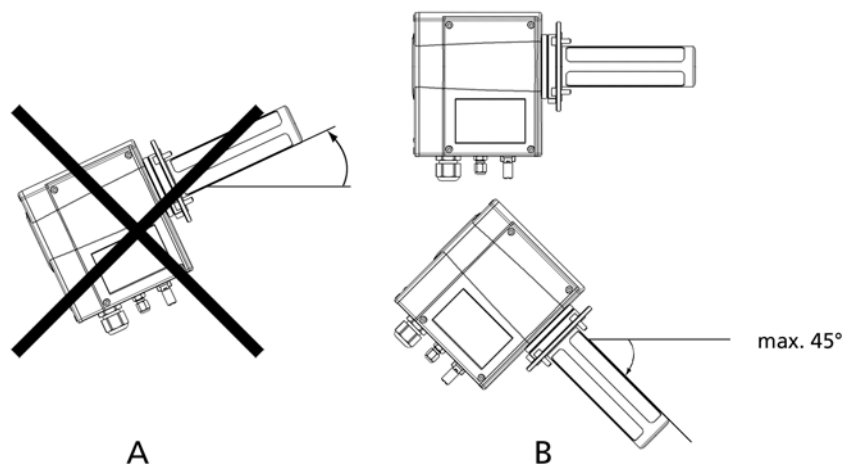
filter is used and the light (for example, the sun) is shining directly to the probe lens or mirror.

Even the stainless steel mesh filter attenuates some ambient light. Usually it is enough to suppress for example normal indoor or laboratory universal lighting. More attenuation and better protection from the effects of exceptionally powerful light sources is provided by the PTFE filter, which should be used for example outdoors in direct sunlight.

## Maximum Allowed Installation Angle

To prevent liquid from entering the optical path, the drain slots of the sensor need to be below the optical components' cavities. This limits installation in high-humidity processes.

For installation in locations of high relative humidity, see [Figure 9 on page 31](#) for installation angle limitations. If process gas is dry (the process temperature is much higher than the dewpoint temperature of the gas) so that there is no risk for condensation, the probe can be tilted quite freely. However, vertical installation of the measurement probe is not recommended when using the sampling cell. With a vertically installed probe and sampling cell, it is possible to encounter some flow-dependency when measuring high O<sub>2</sub> concentrations.



**Figure 9 Installation Angle Limitations in High Humidities**

The following letters refer to [Figure 9 on page 31](#):

- A = In high humidities, installation with probe pointing upwards absolutely prohibited
- B = In high humidities, installation allowed only with probe horizontal or at a maximum downward angle of 45°

## Mounting Options

### Process Conditions in Regard to Mounting Options

The basic version of OMT364 has the following mounting options:

1. Flange mounted for in-line process gas measurement
2. Sampling cell mounted; either
  - with direct feed from the process, or
  - with sample gas treatment system.

The different mounting options have certain limitations regarding process conditions. These are listed in [Table 1 on page 32](#).

Also available is a version of OMT364 specifically designed for ambient gas measurement, see [Mounting the OMT364 for Ambient Gas Measurement on page 41](#) for its installation.

**Table 1 Process Conditions and Mounting Options**

	<b>Flange Mounted (In-Line)</b>	<b>Sampling Cell Mounted, Direct Feed from Process</b>	<b>Sampling Cell Mounted, Sample Gas Treatment System (Filter, Regulator etc.)</b>
Gas velocity (flow rate)	no limitations	no limitations	no limitations
Gas velocity where in-line adjustment is possible	0 ... 20 m/s	no limitations if 3-way valve is installed	no limitations if 3-way valve is installed
Process pressure	0.8 ... 1.4 bar <sub>a</sub>	0.8 ... 1.4 bar <sub>a</sub>	no limitations <sup>1</sup>
Dirt in gas	SS mesh filter: only few large dirt or dust particles	SS mesh filter: only few large dirt or dust particles	no limitations <sup>1</sup>
	PTFE filter: dust, water droplets	PTFE filter: dust, water droplets	no limitations <sup>1</sup>
Process temperature (probe)	-20 ... +80 °C	-20 ... +80 °C	no limitations <sup>1</sup>
Ambient temperature (transmitter)	-20 ... +60 °C	-20 ... +60 °C	-20 ... +60 °C

1. After treatment of gas sample the measurement conditions inside the sampling cell must conform to the specifications of the device, that is they need to be the same as in the above table column "Sampling Cell, Direct Feed from Process".

## CAUTION

Filter clogging must be checked periodically. If the filter is clogged, it must be changed. For more information, see [Filter Change on page 138](#).

## Flange Mounted for In-Line Process Gas Measurement

Mounting OMT364 with a flange is intended for in-line process gas measurement.



**Figure 10** OMT364 Transmitter with Flange Adapter

### Suitable Process Flanges

The maximum diameter of the OMT364 flange adapter is  $\varnothing$  97 mm. It has been chosen to suit the center of a DIN 2572/B flange (mounted with M16 hex bolts). The smallest possible ANSI flange is ANSI 150 2.5" (mounted with 3/4" hex bolts).

The flange can of course be larger than the minimum requirements given above. See [Appendix A, Flange Preparation Instructions, on page 155](#).

### Filter Recommendation

At a minimum, use of the stainless steel mesh filter is recommended. The stainless steel mesh provides protection against coarse dirt such as large specks of dust. If a short response time is not of great importance,

use of the PTFE filter in addition to the stainless steel mesh filter is advised.

The PTFE filter is placed under the stainless steel mesh filter and it is effective at preventing liquid water, dust and other contaminants from entering the optics. The PTFE filter is also effective at attenuating exceptionally powerful ambient and thereby reducing any effects that powerful ambient light has on the oxygen measurement. However, the PTFE filter is still permeable to gases and vapors.

In applications where a very short response time is desired, all filters can be removed. However, when the filters are removed, the optics are openly exposed to contamination and cleaning of the optics may be necessary more often, see [Cleaning the Optics on page 135](#). Removal of filters is not recommended if there is a risk of getting water or dirt on the optics. Before removing the filters, see also section [Powerful Light Sources Near the Oxygen Measurement Probe on page 29](#).

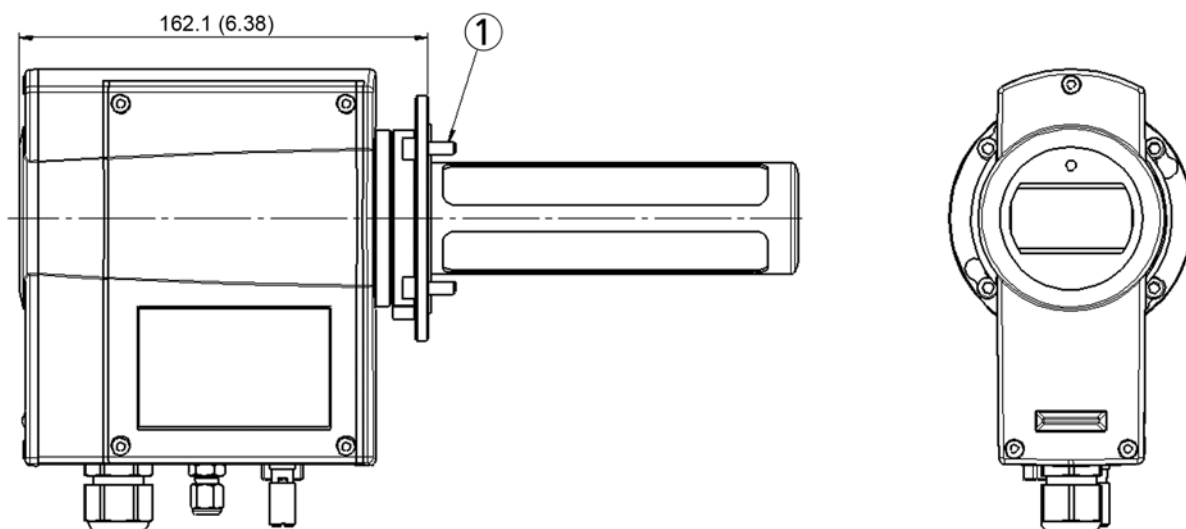
## Mounting with a Flange Adapter

The smallest DIN flange suited for the flange adapter of OMT364 is DIN 2572/B flange (mounted with M16 hex bolts). See [Suitable Process Flanges on page 33](#) for more information on process flanges. The flange adapter is installed at the factory and is held in place by one screw at the bottom of the adapter.

To mount OMT364 using the flange adapter:

1. Prepare four threaded screw holes in the process flange for attaching the flange adapter. See [Figure 19 on page 43](#) for flange adapter dimensions and drilling instructions.
2. Screw the four provided M5 flange adapter fixing screws about half-way in to the threaded holes you have prepared. The flange mounting installation accessories include a flange adapter gasket; check that it sits snugly in its slot in the flange adapter. The gasket between the flange adapter and process flange provides a gas-tight installation.
3. Slide the transmitter through the process flange. Notice you have to tilt the transmitter slightly clockwise in order for the screws to fit through the larger slots of the flange adapter. Tilt the transmitter back to the left to set it in the right position for tightening the screws.
4. Finish the installation by tightening the screws.

Notice that while it is possible to detach the transmitter from the process by removing the screw holding the flange adapter in place, reinstallation of the transmitter in this case is cumbersome. Therefore this procedure is not recommended.



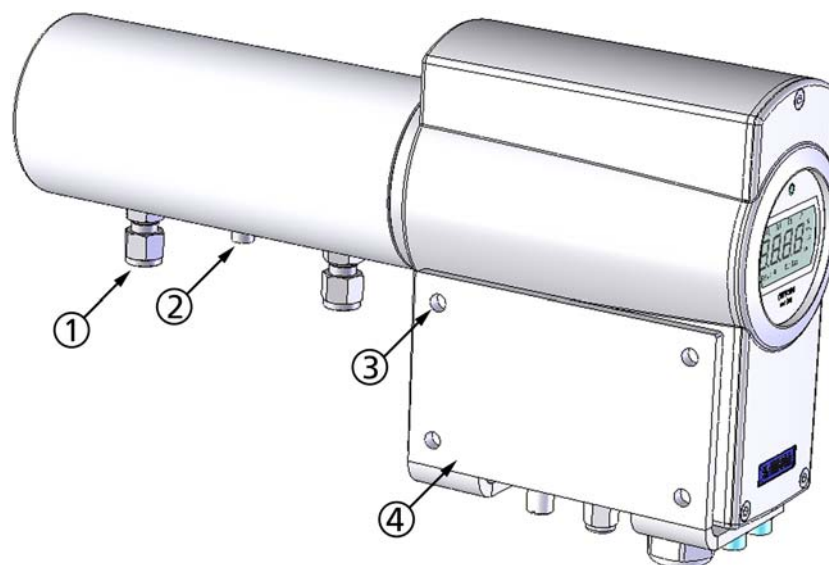
**Figure 11 Dimensions of OMT 364 Flange Mounted**

The following number refers to [Figure 11 on page 35](#):

1 = Max. screw size M5

## Mounting with a Sampling Cell

For processes with high temperatures, elevated pressure or extremely difficult mechanical conditions the sampling cell option of OMT364 can be used. Due to the robustness of the SPECTRACAP<sup>®</sup> sensor and its low sensitivity to gas flow and pressure variations a very simple sampling system can be used.



**Figure 12 OMT364 Transmitter with Sampling Cell**

The following numbers refer to [Figure 12 on page 36](#):

- 1 = Swagelok connectors for  $\varnothing$  6 mm gas tubes or 1/8" NPT thread
- 2 = Drain slot
- 3 = Max. screw size M6
- 4 = Wall mounting bracket

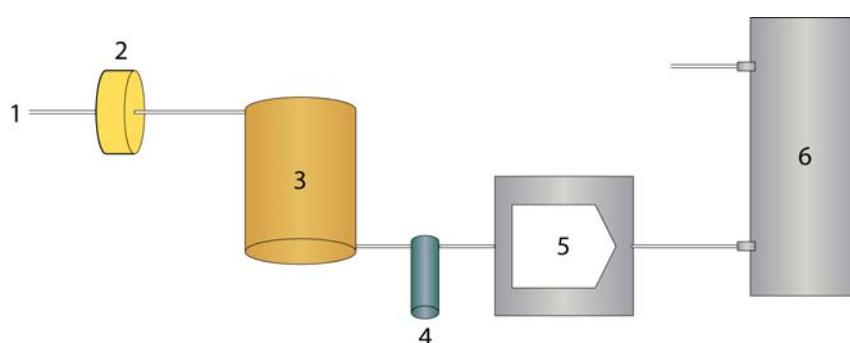
### Filter Recommendation

At a minimum, use of the stainless steel mesh filter is recommended with the sampling cell option. The PTFE filter is recommended if the gas contains moisture or dirt with a fine particle size.

If the process gas is very dirty and humid, the sample gas should be filtered and dried before it is pumped to the sampling cell. A hydrophobic dust filter before the inlet of the sampling cell is needed in order to prevent particles and water from the surroundings from contaminating the optics. The dust filter needs to be changed often enough to provide an adequate flow.

In humid environments it is important to avoid water condensation inside the sampling cell. This can be avoided by drying the sample gas. The most common method of drying the sample gas is cooling and reheating it. A simple system may consist for example of a cooling coil

and a water trap which are either cooled or located in a cool environment, followed by a reheating system. The idea is to get the moisture in the sample to condense on the walls of the copper tube, trap this water and then lower the relative humidity by reheating the sample. If the temperature inside the sampling cell is significantly higher than the surroundings, the cooling coil and the water trap can simply be located outside the sampling cell. For reheating, the heat generated by a pumping system may sometimes be adequate, meaning that no additional heater is needed. A simplified diagram of a sample gas treatment system for removing dirt and moisture is illustrated in [Figure 13 on page 37](#).



**Figure 13 Sample Gas Treatment System**

The following numbers refer to [Figure 13 on page 37](#):

- 1 = Gas in
- 2 = Hydrophobic filter
- 3 = Stainless steel (AISI316) tube coil
- 4 = Water trap
- 5 = Sample pump (EX approved)
- 6 = Oxygen sensor

## Mounting with a Wall Mounting Bracket

The transmitter is mounted with the wall mounting bracket as follows:

1. The wall mounting bracket has four  $\varnothing$  6.5 mm holes for wall attachment with screws or bolts; see [Figure 19 on page 43](#) for wall mounting bracket dimensions. Attach the wall mounting bracket to the desired location using an attachment method appropriate for the building material of the wall (for example, anchor bolts for a concrete wall).

2. Attach the transmitter to the wall mounting bracket using the four M6 screws provided. For easier installation, you can pre-fix the two outer screws to the threads at the bottom of the transmitter as the outer screw holes of the wall mounting bracket are slotted. This way it is easier to attach the two inner screws as you place the transmitter on the wall mounting bracket. Finish the installation by tightening all four screws.

## Tubing Instructions

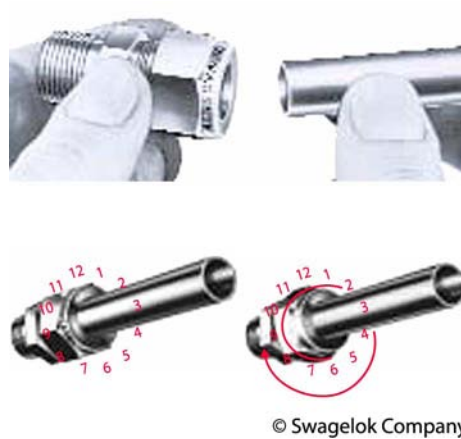
The sampling cell of OMT364 has Swagelok connectors for  $\varnothing$  6 mm gas tubes or 1/8" NPT thread. Use of stainless steel tubing is recommended. Instructions for installing the Swagelok tube fittings are provided below.

Provide adequate support for the tubing, for example by attaching the tubing to the wall. The weight of the tubing must not exert torque on the sampling cell as this could damage the transmitter or cause the wall mounting bracket to come out of the wall.

The incoming gas should be fed through the connector closer to the transmitter side of the sampling cell. This setup should provide better gas exchange at the sensor end of the sampling cell volume and shorten response time.

### Installation Instructions for Swagelok Tube Fittings

1. Insert the tubing into the Swagelok tube fitting. Tubing should rest firmly on the shoulder of the fitting. The nut should be finger tight. See [Figure 14 on page 39](#).
2. Mark the nut at the 6 o'clock position.
3. Hold the fitting body with a backup wrench and tighten the nut 1¼ turns. Watch the marking and make one complete turn and continue to 9 o'clock position.

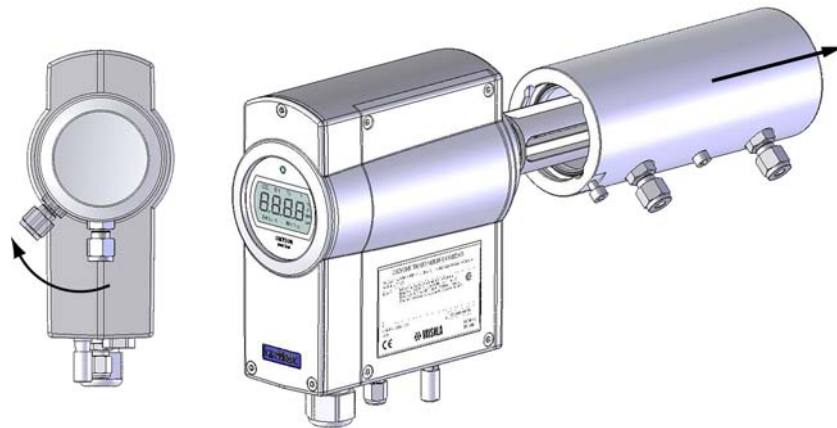


**Figure 14 Swagelok Tube Fitting Instructions**

## Sampling Cell Instructions

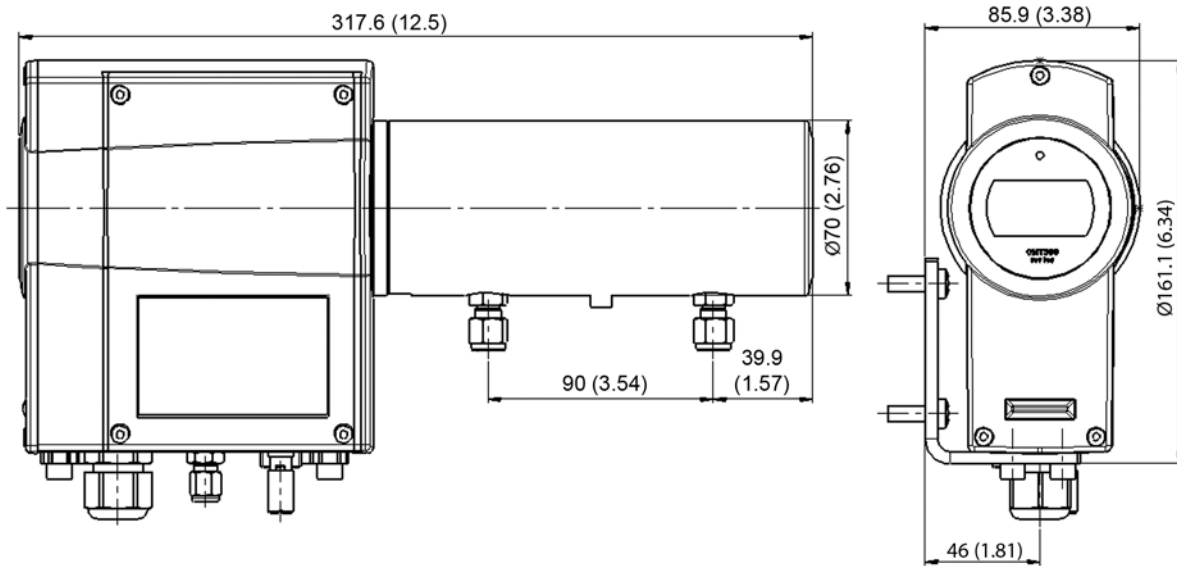
OMT364 with the sampling cell mounting option is delivered with the sampling cell installed at the factory and ready for wall mounting. However, to check and replace the filters, it is necessary to remove and reinstall the sampling cell. The sampling cell is removed and reinstalled as follows:

1. The sampling cell is held in place by a bayonet type fitting. A screw at the bottom of the sampling cell is used to prevent accidental opening. Open the screw and detach the sampling cell: first turn the sampling cell and then pull it clear from the transmitter, see [Figure 15 on page 40](#).
2. To reinstall, simply reverse the procedure. There is a sealing between the sampling cell and transmitter housing. Check that it is in its place when reinstalling the sampling cell. The Swagelok connectors for the sample gas are to face directly downwards.



**Figure 15 Detaching the Sampling Cell**

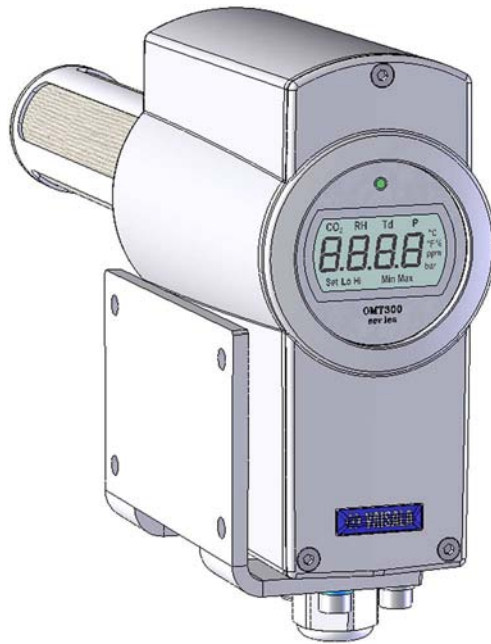
There is a drain slot in the middle of the sampling cell for draining any condensation that might have gathered inside the sampling cell. The slot is plugged with a screw and a small O-ring sealing. If the process conditions are such that a lot of condensation is to be expected inside the sampling cell, it is recommended that you install a valve in the drain slot for draining the condensed water from the sampling cell.



**Figure 16 Dimensions, OMT364 with Sampling Cell**

## Mounting the OMT364 for Ambient Gas Measurement

This version of OMT364 is intended specifically for ambient gas measurement. It can be easily mounted on a wall using the wall mounting bracket.



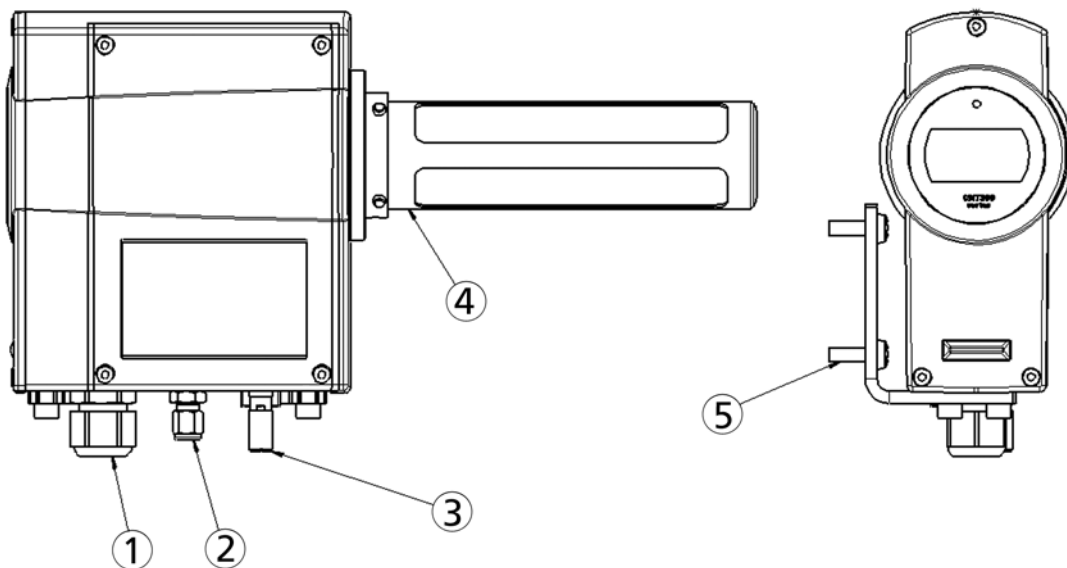
**Figure 17** OMT364 for Ambient Gas Measurement with Wall Mounting Setup

## Mounting Instructions

The transmitter is mounted with the wall mounting bracket as follows:

1. The wall mounting bracket has four  $\varnothing$  6.5 mm holes for wall attachment with screws or bolts; see [Figure 19 on page 43](#) for wall mounting bracket dimensions. Attach the wall mounting bracket to the desired location using an attachment method appropriate for the building material of the wall (for example, anchor bolts for a concrete wall).
2. Attach the transmitter to the wall mounting bracket using the four M6 screws provided. For easier installation, you can pre-fix the two outer screws to the threads at the bottom of the transmitter as

the outer screw holes of the wall mounting bracket are slotted. This way it is easier to attach the two inner screws as you place the transmitter on the wall mounting bracket. Finish the installation by tightening all four screws.

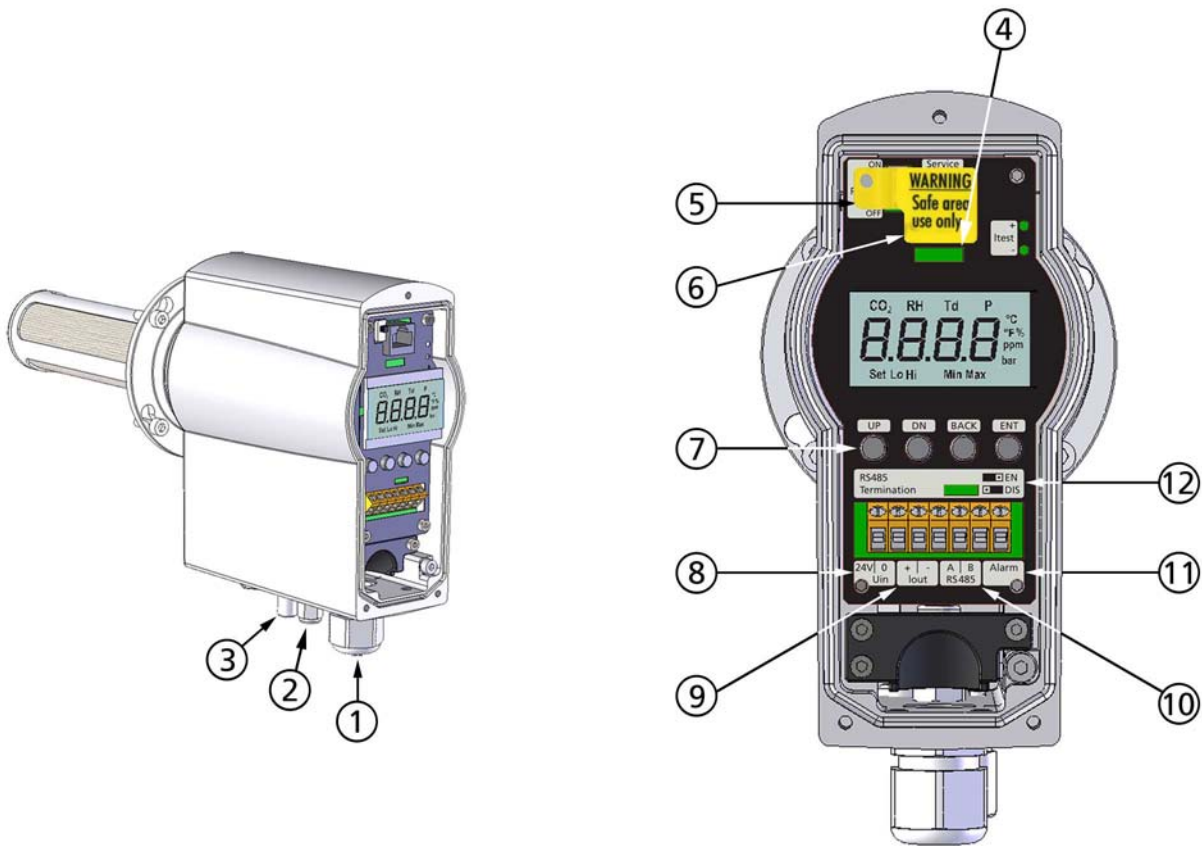


**Figure 18 OMT364 Wall Mounted**

The following numbers refer to [Figure 18 on page 42](#):

- 1 = M20 × 1.5 cable gland for power and signal wires
- 2 = Calibration gas inlet with  $\varnothing$  6 mm Swagelok connector (optional)
- 3 = External grounding connector
- 4 = Stainless steel mesh filter
- 5 = Max. screw size M6





**Figure 20 Connections/Local Interface Layout**

The following numbers refer to [Figure 20 on page 44](#):

- 1 = Conduit fitting
- 2 = Calibration gas inlet (optional)
- 3 = Grounding terminal
- 4 = LED
- 5 = Power ON/OFF switch (do not use in hazardous areas)
- 6 = Service Interface RS232C (do not use in hazardous areas)
- 7 = Local Interface keypad push buttons
- 8 = Supply voltage terminals
- 9 = Current output terminals
- 10 = RS-485 terminals
- 11 = Relay contact terminal
- 12 = RS-485 line termination jumper

1. Open the transmitter back cover. Make sure that the **Power ON/OFF** switch is in the **ON** position (located beneath the yellow protective cover). It is not allowed to use the switch in a hazardous area due to a risk of sparking.
2. Slide in the cable through the bushing in the bottom of the transmitter. To avoid damage and sparking, the cable **MUST BE UNPOWERED**.
3. Connect the supply voltage between the terminals **Uin (24V)** and **(0)**.
4. Current output is available between the terminals **Iout (+)** and **(-)**. Current output can be tested by connecting an ammeter between the test points ITEST+ and ITEST- when output is loaded.
5. Two wire RS-485 is available between the terminals **RS 485 (A)** and **(B)**. Line termination can be enabled by changing the **RS485 Termination** jumper position to **EN**.
6. Floating relay contact is available between the two **Alarm** terminals. Additional information is given in sections [Test Alarm Relay Function \(Ala\) on page 79](#) and [Show/Set Relay Operating Mode Command \(RELAY\\_MODE\) on page 78](#).
7. Make sure the **Power ON/OFF** switch is in the **ON** position. Then turn on the supply voltage from the power supply in safe area.
8. The transmitter starts performing the self test. The text "PASS" is displayed when the self-test is completed. It takes a short while after the self-test before the device is ready for measurement and starts displaying oxygen readings. A green LED lights up after the transmitter has found the absorption line and a valid measurement can be made.
9. When the self test has successfully been completed, close the transmitter back cover. The transmitter is now ready for use.



## CHAPTER 5

# OPERATION

This chapter contains a description of the device interfaces and the software commands.

Read the instructions through carefully before making any adjustments or parameter changes. Vaisala accepts no responsibility for parameter or settings changes nor adjustments made by the user. When you require technical support or assistance, please contact Vaisala Technical Support (see [Technical Support on page 149](#)).

## Device Interfaces

### Power Supply

Supply voltage is 11 ... 36 VDC. The transmitter cannot be used with AC voltage. Note that the power supply interface is galvanically isolated from other electronics.

### Keypad, Display and LEDs

OMT364 transmitter has a seven segment display and four push buttons inside its housing. The local display shows the oxygen reading, but through the user interface you can gain access to basic functions such as calibration and adjustment, analog output scaling and so on.

During operation the operating stage of the transmitter is also indicated by LEDs. Continuously lit green LED indicates normal operation, for other LED indications, refer to section [Operation Errors on page 141](#).

The keypad push buttons are indicated as **Up**, **Dn**, **Back** and **Ent**:

**Up** - up key

**Dn** - down key

**Back** - back key

**Ent** - enter key

See [Figure 20 on page 44](#) and [Figure 21 on page 50](#) for keypad and display layout.

## Service Interface

### **WARNING**

Do not use the service interface in hazardous areas, only in a safe area.

The transmitter has an RS232C serial port for service functions. You can access all adjustable parameters with a PC terminal program through the Service Interface. The transmitter can be connected to a PC by using either a RS232C serial interface cable (Vaisala order code: 19446ZZ) or a RS232C-to-USB serial interface cable (Vaisala order code: 219685). If you need to reconfigure device alarm level(s), Customer Interface or other settings, the Service Interface provides a wider range of options than the keypad and display functions.

### Installing the Driver for the USB Cable

Before taking the USB cable into use, you must install the provided USB driver on your PC. When installing the driver, you must acknowledge any security prompts that may appear. The driver is compatible with Windows 2000, Windows XP, Windows Server 2003, and Windows Vista.

1. Check that the USB cable is not connected. Disconnect the cable if you have already connected it.
2. Insert the media that came with the cable, or download the driver from [www.vaisala.com](http://www.vaisala.com).

3. Execute the USB driver installation program (setup.exe), and accept the installation defaults. The installation of the driver may take several minutes.
4. After the driver has been installed, connect the USB cable to a USB port on your PC. Windows will detect the new device, and use the driver automatically.
5. The installation has reserved a COM port for the cable. Verify the port number, and the status of the cable, using the **Vaisala USB Instrument Finder** program that has been installed in the Windows Start menu. The reserved ports are also visible in the **Ports** section of the Windows Device Manager.

Remember to use the correct port in the settings of your terminal program. Windows will recognize each individual cable as a different device, and reserve a new COM port.

There is no reason to uninstall the driver for normal use. However, if you wish to remove the driver files and all Vaisala USB cable devices, you can do so by uninstalling the entry for **Vaisala USB Instrument Driver** from the **Add or Remove Programs (Programs and Features** in Windows Vista) in the Windows Control Panel.

## Customer Interface

OMT364 transmitter has a nonisolated two wire RS-485 serial port for customer interface use. According to the standard, you can loop up to 32 transmitters for 1 km, by using just one twisted pair. The system can request oxygen data by polling addressed transmitters.

## Analog Output

OMT364 transmitter has a nonisolated current output. The analog output is configured according to order either from 0 or 4 to 20 mA. Also fault states are determined at order time. All of these parameters can later be updated by the customer through Service Interface.

## Relay

OMT364 transmitter has one encapsulated contact relay. It can be configured at order time to operate as a level indicator or only as a device failure indicator. These functions can also be updated later on.

**NOTE**

The contact relay is of a non-latching type.

## Local Interface (Keypad and Display)

### Features

The main purpose of the local (keypad/display) interface is field calibration. It is also possible to set process pressure, humidity and carbon dioxide content to achieve better accuracy of measurement. Also the analog outputs can be forced to certain states for a system test.

OMT364 transmitter has a seven segment display (operating temperature range -20 ... +60 °C), four push buttons and one two-color LED (red/green). The interface supports only metric units.

Access control for the Local Interface is achieved by requiring a password to change the parameters. After the password has been given it is valid for 30 minutes.

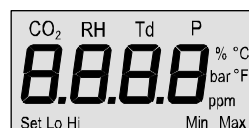


Figure 21 OMT364 Display Layout

**NOTE**

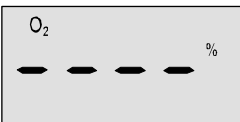
Some LCD segments are not utilized during operation of OMT364.

## Display Modes

Without any user action the display is in one of the following modes:

## Start-Up

Text indicating the software version is displayed. After this the self-test will commence and the text "SELF TEST" scrolls on the display. When self-test is complete, the text "PASS" is displayed and a warm-up period begins. When warm-up is complete, oxygen measurement starts. A blank display is shown first, followed by the oxygen measurement reading. The entire start-up sequence takes approximately 2.5 minutes.

A rectangular digital display showing the number "1.00" in a black, monospaced font on a light gray background.A rectangular digital display showing the word "SELF" in a black, monospaced font on a light gray background.A rectangular digital display showing the word "TEST" in a black, monospaced font on a light gray background.A rectangular digital display showing the word "PASS" in a black, monospaced font on a light gray background.A rectangular digital display showing a series of seven vertical bars of varying heights, representing a warm-up or calibration sequence.A rectangular digital display showing "O<sub>2</sub>" on the left and "%" on the right, with a blank space in the center for an oxygen measurement reading.

## Normal Operation

Oxygen measurement reading is displayed.



## Error Condition

Error condition number is displayed.



## Warning

The green LED is blinking slowly and oxygen concentration reading is shown. Choose **Err** function from the menu or use serial line commands to see the error message.



## Service Interface

**NOTE**

Safe area use only.

The Service Interface is intended for service and calibration use as well as for changing parameters.

The Service Interface connector is a RJ45 type connector located above the display on the connector board. Protocols, standards and command

formats are the same as with Customer Interface (however, the default operation mode for the Service Interface is the STOP mode), see [Customer Interface on page 53](#).

Basic commands are available for all users but, for example calibration and adjustment, scaling, and restoring factory settings require a password.

## Customer Interface

This interface is intended for customer use. The interface is available on the transmitter connector board. It is a two-wire RS-485 interface without galvanic isolation. There are also switchable line termination resistors. Use a jumper to enable or disable the line termination.

There are three separate operation modes: STOP, POLL and RUN. The RS-485 interface supports the standard Vaisala Instruments command set with additional device specific commands.

The default mode of operation is the POLL mode. RUN mode is the continuous printing mode. You can set the parameters to be printed and the print interval. Then in RUN mode the device prints out the results at the given interval. No commands are answered except the **S** command, which stops RUN mode and switches the device into STOP mode.

POLL mode is dedicated for bus interfacing. Each device must have its own unique address and one device at a time is first opened for communication and then closed before accessing another device on the same bus. To enter the mode, first use the **CLOSE** command and then to gain control of a device, use the **OPEN** command with the address of the device as the command parameter.

Access controls are the same as with Service Interface.

## Functions

### General Instructions for Using Functions

Functions are used through the Local Interface. Access (activate) the menu with the **Up** or **Dn** keys. Activate the functions by pressing the



**Ent** key, use the **Up/Dn** keys to scroll through the menu. If you have to interrupt your operation use the **Back** key.

Numeric values are fed (if no other method is mentioned) by using the **Up/Dn** keys. The **Up** key scrolls through the digits, increasing the digit by one with each press of the key. The **Dn** key switches between the digits on the display.

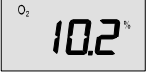
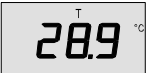




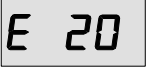


## Menu Structure












Without the password the menu structure looks like this (Press **Dn** key to scroll down in the menu):

Main function	Display	Subfunction
Oxygen statistics display		Show current O <sub>2</sub>
		Show/clear max O <sub>2</sub>
		Show/clear min O <sub>2</sub>
Temperature statistics display		Show current T
		Show/clear max T
		Show/clear min T
Calibration check		
		Show current O <sub>2</sub> reference gas value with frozen analog output
Signal level display		
		Show signal strength
Error display		
		Show unexpired error 1 Show unexpired error 1 ... Show unexpired error N

Main function	Display	Subfunction
Password		
		Ask password

Menu structure when password has been given:

Main function	Display	Subfunction 1	Subfunction 2
Oxygen statistics display		Show current O <sub>2</sub>	
		Show/clear O <sub>2</sub> max	
		Show/clear O <sub>2</sub> min	
Temperature statistics display		Show current T	
		Show/clear max T	
		Show/clear min T	
Calibration check		Show current O <sub>2</sub> reference gas value with frozen analog output	
Signal level display			
		Show signal strength	
Error display			
		Show unexpired error 1 Show unexpired error 2 ... Show unexpired error N	
Set password			
		Show password Change password	

Utility function	Display	Subfunction 1	Subfunction 2
Set (average) process pressure			
		Show pressure setting Change pressure setting	
Set (average) water content H <sub>2</sub> O			
		Show water content setting Change water content setting	
Set (average) CO <sub>2</sub> content			
		Show CO <sub>2</sub> setting Change CO <sub>2</sub> setting	
One point calibration			
		Set calib. gas 1	Set calib. gas / calibrate
Two point calibration			
		Set calib. gas 1	Calibrate 1
		Set calib. gas 2	Calibrate 2

Test analog output	ADU		
	0.00 <small>Set</small>	Show output current: normal stage, forced outputs: 0, 4, 12, 20 mA Change output current	Display existing current output or set forced output 0, 4, 12, 20 mA
	4.00 <small>Set</small>		
	12.00 <small>Set</small>		
	20.00 <small>Set</small>		
Restore factory calibration	FAC	Restore factory calibration, sets gain = 1, offset = 0	
Scale analog output	ASCL	Start scaling	Accept function
	O <sub>2</sub> 000.0 <small>Set Lo</small>	Show O <sub>2</sub> equivalent to 0 or 4 mA	Change scale
	O <sub>2</sub> 020.0 <small>Set Hi</small>	Show O <sub>2</sub> equivalent to 20 mA	Change scale
Test alarm relay	ALA	Show relay state	
	OPE <small>Set</small>	Change relay state	
	CLO <small>Set</small>		
Reset transmitter	OFF	Reset	
	RESET		

## Serial Commands

Serial commands are the same for both Service Interface and Customer Interface. The meaning of the command line elements is presented in the table below.

**Table 2**      **Meaning of the Command Line Elements**

Element	Meaning	Text Style Used
<b>SAMPLE</b>	Specifies the name of the command or utility.	<b>UPPER CASE BOLD</b>
{variable}	Indicates a set of choices from which the user must choose one, several or all.	lower case enclosed in {braces}
[option]	Indicates optional items.	lower case enclosed in [brackets]
., : ;	Punctuation marks are considered as part of the command and should be included as they are.	lower case
<cr>	Stands for pressing Enter (on your computer keyboard)	lower case

**Table 3**      **OMT364 Default Serial Communication Settings**

Property	Description / Value
Baud rate	19200
Data bits	8
Parity	none
Stop bits	1

## List of Serial Commands

**Table 4 List of Serial Commands without Password**

Serial Command	Description
?	Shows information about the device.
??	Shows information in the device, overriding POLL mode.
ADDR	Shows/sets device address.
CALCS	Shows measuring parameters.
CINFO	Shows calibration information.
CLOSE	Closes serial line (POLL mode).
DATE	Shows/sets date.
ECHO	Sets echoing mode.
ERRS	Shows detected errors.
FORM	Sets output format.
HELP	Lists commands.
INTV	Shows/sets continuous output interval.
OPEN	Opens communications line.
PARAM	Shows all modifiable parameter values.
PASS	Issues password.
R	Starts continuous output.
S	Stops continuous output.
SAVE	Saves parameters to EEPROM.
SEND	Sends measurement results.
SERI	Shows/sets serial communication settings.
SERI2	Shows/sets serial communication settings for line 2.
SIL	Measures signal level.
SMODE	Shows/sets serial communications mode.
SMODE2	Shows/set. serial communications mode for line 2.
STATS	Shows statistical information.
TIME	Shows/sets time.
VERS	Shows product name and software version.
XPRES	Sets pressure for compensation.

**Table 5 List of Additional Serial Commands with Password Given**

Serial Command	Description
ADJUST	Locks outputs for calibration.
CO2	Shows/sets CO <sub>2</sub> for compensation.
COXY1	Makes one-point adjustment.
COXY2	Makes two-point adjustment.
DB	Shows display board status.
ENV	Sets several/all environmental parameters with single command.

**Table 5 List of Additional Serial Commands with Password Given**

Serial Command	Description
ERR	Shows error control status.
ERRL	Shows error log.
ERRT	Shows error table.
FCRESTORE	Restores factory calibration.
H2O	Shows/sets H <sub>2</sub> O for compensation.
ICAL	Calibrates analog output.
ITEST	Sets test current to analog output.
LTC	Shows laser temperature controller status.
MEA	Shows measurement status.
OUT	Shows output status.
OUT_PARAMS	Shows/sets output parameters.
PRES	Shows/sets pressure for compensation.
RELAY_MODE	Shows/sets relay operating mode.
RESET	Resets device.
RSEL	Shows/sets relay trigger points.
SCI1	Shows serial line 1 status.
SCI2	Shows serial line 2 status.
STATUS	Shows status of subfunctions.

## Outputting Measurement Results

### Start Continuous Output Command (R)

This command starts the RUN mode where results (defined with command **FORM**) are printed with the interval set with command **INTV**. RUN mode printing can be stopped by using the **S** command or by pressing the **Esc** key.

Syntax: **R**<cr>

#### Example:

```
>r
Oxygen = 21.0
Oxygen = 21.0
Oxygen = 21.0
```

## Stop Continuous Output Command (S)

This command stops the RUN mode and switches serial mode to STOP.

Syntax: **S**<cr>

### Example:

```
>S  
>
```

## Show/Set Continuous Output Interval Command (INTV)

This command sets the interval between result outputs in RUN mode.

Syntax: **INTV** [value] [unit]<cr>

where

value = Time interval between the result outputs  
(0 ... 255)

unit = Time unit of the interval, S for seconds, MIN for minutes or H for hours

### Example:

```
>intv  
INTERVAL : 1 ? 5  
UNIT : S ? min
```

## Send Measurement Results Command (SEND)

This command prints out the latest result (according to **FORM**) in STOP mode. The command can be used with an address in POLL mode.

Syntax:

**SEND** [address]<cr>

**SEND** [form\_string]<cr>

where

address = Device address

form\_string = Format string specifying the output format of the measurement result

**Example:**

```
>send
  20.9   20.8   24.5
```

## Show/Set Serial Communications Mode Command (SMODE)

This command sets the serial communications mode. The command sets the serial mode of the interface that the command is issued from (Service Interface or Customer Interface). Possible modes are STOP, POLL and RUN. Issue **SAVE** command to save the setting.

Syntax: **SMODE** [mode]<cr>

where

mode = Serial communications mode, possible modes are STOP, POLL and RUN

**Example:**

```
>smode
SMODE      : STOP ?
>
```

## Show/Set Serial Communications Mode for Line 2 Command (SMODE2)

This command sets the customer interface (Customer Interface) communications mode. Possible modes are STOP, POLL and RUN. Issue **SAVE** command to save the setting.

Syntax: **SMODE2** [mode]<cr>

where

mode = Serial communications mode, possible modes are STOP, POLL and RUN

### Example:

```
>smode2
SMODE      : STOP ?
>
```

## Show/Set Serial Communications Settings Command (SERI)

This command sets the parameters for serial communications.

**NOTE**

The command sets the parameters of the interface that the command is issued from (Service Interface or Customer Interface).

Valid baud rates for Service Interface are 300, 600, 1200, 2400, 4800, 9600, 19200, 38400, 57600 and 115200. For Customer Interface, the maximum baud rate is 38400.

**NOTE**

The changed settings must be saved to EEPROM and the device must be reset before the new settings are taken into use.

Syntax: **SERI** [baud] [data] [parity] [stop]<cr>

where

baud = Baud rate, valid baud rates are 300, 600, 1200, 2400, 4800, 9600, 19200, 38400, 57600 and 115200 (for Customer Interface, max. baud rate is 38400)

data = Number of data bits (7 or 8)

parity = Parity (n = none, e = even, o = odd)

stop = Number of stop bits (1 or 2)

**Example:**

```
>seri
BAUD RATE      : 19200 ?
DATA BITS      : 8      ?
PARITY         : NONE ?
STOP BITS      : 1      ?
```

## Show/Set Serial Communication Settings for Line 2 Command (SERI2)

This command sets the parameters for the Customer Interface. This command can be given from the Service Interface. Valid baud rates are 300, 600, 1200, 2400, 4800, 9600, 19200, and 38400.

**NOTE**

The changed settings must be saved to EEPROM and the device must be reset before the new settings are taken into use.

Syntax: **SERI2** [baud] [data] [parity] [stop]<cr>

where

baud = Baud rate, valid baud rates are 300, 600, 1200, 2400, 4800, 9600, 19200, and 38400

data = Number of data bits (7 or 8)

parity = Parity (n = none, e = even, o = odd)

stop = Number of stop bits (1 or 2)

**Example:**

```
>seri2
BAUD RATE      : 19200?
DATA BITS      : 8      ?
PARITY         : NONE ?
STOP BITS      : 1      ?
```

## Show Serial Line 1 Status Command (SCI1)

This command displays and sets the status of the service interface object and related variables.

Syntax: **SCI1**<cr>

**Example:**

```
>scil
*** SERVICE INTERFACE (SCI1) ***:
Mode          : STOP
Seri          : 19200 8 NONE 1

SERI          : 19200 8 NONE 1
ECHO          : ON
SMODE         : STOP
```

## Show Serial Line 2 Status Command (SCI2)

This command displays the status of the customer serial interface object and related variables.

Syntax: **SCI2**<cr>

**Example:**

```
>sci2
*** CUSTOMER INTERFACE (SCI2) ***:
Mode          : STOP
Seri          : 19200 8 NONE 1

SERI          : 19200 8 NONE 1
ECHO          : ON
SMODE         : STOP
```

## Show Measurement Status Command (MEA)

This command displays the status of the measurement object and related variables.

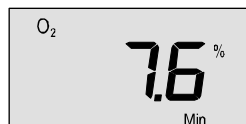
Syntax: **MEA**<cr>

### Example:

```
>mea
*** OXYGEN MEASUREMENT (MEA) ***
Mode           : NORMAL
State          : PEAK_SEARCH
OP (DAC/mA)    : 20960 / 1.92
...
```

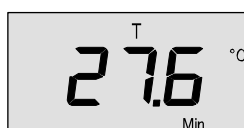
## Oxygen Statistics Display Function

The oxygen statistics display function can be selected by pressing **Ent** when oxygen reading is displayed. Use the **Up/Dn** keys to scroll between, min and max O<sub>2</sub> reading displays. When min or max is on the display and **Ent** is pressed, the digits start to blink. Pressing the **Ent** key one more time clears the record in question.



## Temperature Statistics Display Function

The temperature statistics display function works in the same way as the oxygen statistics display function. Use the **Up/Dn** keys to scroll between min, and max temperature reading display. When min or max is on the display and **Ent** is pressed, the digits start to blink. Pressing the **Ent** key one more time clears the record in question.



## Formatting Measurement Results

### Set Output Format Command (FORM)

The **FORM** command specifies the configuration of output format for commands **SEND** and **R**. Users can modify the output format to suit their individual needs.

Syntax: **FORM** [x]<cr>

where

x = Format string

Format string consists of quantities and modifiers. You can select one or more of the following quantities by typing the abbreviation after **FORM** command:

**Table 6 Format String Abbreviations and Quantities**

Abbreviation	Quantity
O2	Filtered O <sub>2</sub> results
TGASC	Gas temperature (Celsius)
TGASF	Gas temperature (Fahrenheit)
TIME	Time elapsed since last reset
DATE	Date (user-set, follows time elapsed since last reset)
ERR	Error category (0 = no error, 1 = nonfatal, 2 = fatal)
ADDR	Transmitter address (0 ... 99)

Modifiers are as follows:

**Table 7 Format String Modifiers**

Modifier	Description
x.y	Length modifier (whole numbers and decimal places). All subsequent quantities use the modified length parameters.
\t	Tabulator
\r	Carriage return
\n	Line feed
\xxx	Any character code (three decimal value)
""	String constant
U5	Unit field and length, U without length will output units in default width

**NOTE**

Alternative token for \ is #.

**Examples:**

Configuring an output format consisting of the oxygen measurement result (displayed with three decimal places) along with the gas temperature in degrees Celsius (also displayed with three decimal places), text strings are included after the readings to represent the output units. Notice how the tabulator '\t' is used to separate the different

modifiers and the carriage return '\r' tag is used in the end of the line to return a new row for each outputted measurement result. Issue **SAVE** command to save the setting:

```
>form 2.3 O2 \t "%O2" \t 2.3 TGASC \t "C" \r \n
>save
EEPROM (basic) saved successfully
EEPROM (op) saved successfully
EEPROM (op_log1) saved successfully
EEPROM (op_log2) saved successfully
>send
2.504 %O2 28.065 C
```

Command **FORM** without parameters outputs the current form string:

```
>form
2.3 O2 \t "%O2" \t 2.3 TGASC \t "C" \r \n
```

Command **FORM /** returns default output form:

```
>form /
F0
>send
Oxygen = 21.0
```

## Show/Set Date Command (DATE)

This command sets the date.

Syntax: **DATE** [yyyy] [mm] [dd]<cr>

where

yyyy	=	Correct year
mm	=	Correct month
dd	=	Correct day

### Example:

```
>date
YEAR      : 2003 ?
MONTH     : 7 ?
DAY       : 17 ?
>
```

**NOTE**

There is no real-time clock in the device so the date set by the user resets always to 0000-01-01 at power on.

## Show/Set Time Command (TIME)

This command displays the time elapsed since the device was last turned on. The time can be set to reflect real time by giving the current time as a parameter. The timer changes from 23:59:59 to 00:00:00.

**NOTE**

For precision measurements please use some other means of measuring time. There is no real-time clock in the device so the time set by the user resets always to 00:00:00 at power on.

Syntax: **TIME** [hh:mm:ss]<cr>

where

hh           = Hours  
mm           = Minutes  
ss           = Seconds

**Examples:**

```
>time  
03:28:32  
>time 11:23:01  
11:23:01  
>
```

## Networking Operation

### Show/Set Device Address Command (ADDR)

This command sets the device address for use on a bus. A unique address must be given to a device before it is attached to a bus. After closing communications with the **CLOSE** command the address must

be known to be able to open communications again. Remember to issue **SAVE** command to save the setting.

Syntax: **ADDR** [address]<cr>

where

address = The device address, range 0 ... 99 (default = 0)

## Open Communications Line Command (OPEN)

This command opens communications to a device with the specified address. The device switches serial mode from POLL to STOP. The address of the opened device is included in the answer message. In the example, the text in *italics* is not echoed unless the user is using local echo.

Syntax: **OPEN** {addr}<cr>

where

addr = Device address

### Example:

```
>open 4
```

```
OMT300: 4 line opened for operator commands
```

```
>
```

## Close Serial Line in Poll Mode Command (CLOSE)

This command closes a device and switches it into POLL mode. Unless an addressable command is issued all output is suppressed until a reset occurs or the **OPEN** command is used. If serial mode is set to POLL using **S.MODE** command and the setting is saved to EEPROM (**SAVE** command), the device wakes up after a reset still in POLL mode and output is suppressed also on start-up.

Syntax: **CLOSE**<cr>

**Example:**

```
>close  
line closed
```

## Set Echoing Mode Command (ECHO)

This command sets the echoing mode. In RS232C mode the device echoes everything back to the user by default. In RS-485 mode echoing is automatically disabled. In the example below, the two commands in *italics* are typed by the user but not seen on the screen unless using local echo.

Syntax: **ECHO** [on/off]<cr>

where

on	=	Echo on
off	=	Echo off

**Example:**

```
>echo off  
  
vers  
  
OMT300 / 1.02  
  
echo on  
  
ECHO      : ON  
>
```

## Accessing Service Level Commands

### Issue Password Command (PASS)

By issuing password it is possible to set access level to BASIC or SERVICE. If issued password is valid for opening service level, it is opened for 30 minutes and service level commands can be accessed. All other passwords or command **PASS** without parameter set basic level.

Syntax: **PASS** [password]<cr>

#### Example:

```
>pass 1010  
>
```

After issuing the password, service level is open for all interfaces, meaning that if you issue the password through the serial line, service level commands can be accessed through the Local Interface as well, and vice versa. When the password expires, a notification is sent once through the serial line (only in STOP mode):

NOTE: PASSWORD EXPIRED

### Issue Password Function (Pas)

Password is required to access certain functions, such as calibration and scaling the outputs through the Local Interface. The password is four digits long ("XXXX").

When the password function **Pas** has been selected the digits '0000' are displayed. Select the password by scrolling through the digits with the **Up/Dn** keys. Confirm the password by pressing **Ent**.





After issuing the password, the service level is open for all interfaces, meaning that if you issue the password through the Local Interface, service level commands can be accessed through the serial line as well, and vice versa.

**NOTE**

When you have issued the password through the Local Interface, it is recommended that you return to the oxygen statistics display after you have finished using the password protected functions. Even though the password expires in 30 minutes, the service level functions can still be accessed after this time period until you move back to the basic level functions in the menu structure.

There is no notification of an expired password through the Local interface.

**NOTE**

Password "1010" opens the service level. If you want to restrict access to this password, remove this page from the manual for safe-keeping.

## Analog Output Calibration

### Calibrate Analog Output Command (ICAL)

This command is used to calibrate the current output. The command calculates and sets values for gain and offset parameters GI and OI.

Syntax: **ICAL**<cr>

**Example:**

```
>ical
Ilow (mA) ? 3.42
Ihigh (mA) ? 17.6
>
```

## Analog Output Scaling and Settings

### Scale Analog Output Function (Ascl)

The analog output can be scaled freely with the scale analog output function. For example, you may set 0.00 mA  $\Leftrightarrow$  3 %O<sub>2</sub> and 20.00 mA  $\Leftrightarrow$  7 %O<sub>2</sub>.

When the scale analog output function **Ascl** has been selected the low end value (at 0.00/4.00 mA) is displayed, which can then be adjusted with the **Up/Dn** keys. The value is accepted by pressing **Ent**. The high end is scaled in the same way.

The analog output scaling mode is stopped by pressing the **Back** key or by time-out (five minutes).

A rectangular LCD display showing the text "ASCL" in a large, bold, monospaced font.A rectangular LCD display showing "O<sub>2</sub>" at the top left, "000.0%" in the center, and "Set Lo" at the bottom left.A rectangular LCD display showing "O<sub>2</sub>" at the top left, "020.0%" in the center, and "Set Hi" at the bottom left.

### Show/Set Output Parameters Command (OUT\_PARAMS)

This command sets analog output related parameters.

Syntax: **OUT\_PARAMS**<cr>

**Example:**

```
>out_params
NONFATALI (mA) : 3.000   ?
FATALI (mA)   : 2.000   ?
I4            : 1       ?
OUTMAXO2 (%)  : 20.000  ?
OUTMINO2 (%)  : 0.000   ?
```

where

NONFATALI = Output current (in mA) in case of nonfatal error

FATALI = Output current (in mA) in case of fatal error

I4 = Parameter used to set whether the current output range starts from 0 or 4 mA:

when I4 = 0, then the current output is 0 ... 20 mA

when I4 = 1, then the current output is 4 ... 20 mA

OUTMAXO2 = Oxygen concentration OUTMAXO2 (%) is set to correspond to current output 20 mA

OUTMINO2 = Oxygen concentration OUTMINO2 (%) is set to correspond to current output 0/4 mA

## Analog Output Testing

### Set Test Current to Analog Output Command (ITEST)

This command starts or stops current output test mode.

Syntax: **ITEST** [current]<cr>

where

current = Test current (mA)

**Example:**

```
>itest 4
Test current set at 4 mA. Use ITEST to stop test mode.
>itest
Current test mode stopped.
>
```

## Test Analog Output Function (Aou)

When the test analog output **Aou** mode has been selected the analog output displays first the existing current output and then it can be forced first to a 0.00 mA output current stage by pressing **Ent**. The same value is also displayed ("0.00"). By pressing the **Up/Dn** keys the output can be switched to output values 0.00 mA, 4.00 mA, 12.00 mA or 20.00 mA.

The test mode is stopped by pressing the **Back** key or by time-out (five minutes).



AOU



0.00  
Set



4.00  
Set



12.00  
Set



20.00  
Set

## Relay Operation

### Show/Set Relay Operating Mode Command (RELAY\_MODE)

This command sets the relay operating mode. See also command [Show/Set Relay Trigger Points Command \(RSEL\)](#) on page 78.

Syntax: **RELAY\_MODE** [fault\_alarm / high\_open / low\_open]<cr>

where

fault\_alarm = Relay open if a fault exists

high\_open = Relay open when measurement result is above high point

= Relay closed when measurement result is below low point

low\_open Relay open when measurement result is below low point

Relay closed when measurement result is above high point

**NOTE**

Relay is of a non-latching type.

### Show/Set Relay Trigger Points Command (RSEL)

This command sets the relay trigger levels.

Syntax: **RSEL**<cr>

**Example:**

```
>rsel
LO POINT (%02) : 10.0    ?
HI POINT (%02) : 11.0    ?
```

## Test Alarm Relay Function (Ala)

When the test alarm relay function **Ala** has been selected the current status of the relay "OPE" (open) or "CLO" (close) is displayed. By pressing the **Ent** key the text starts to blink and it is possible to change the value with the **Up/Dn** keys.

The test alarm relay mode is stopped by pressing the **Back** key or by time-out (five minutes).

A rectangular display box with a light gray background. The text "ALA" is displayed in a large, black, monospace font.A rectangular display box with a light gray background. The text "OPE" is displayed in a large, black, monospace font. Below the text, the word "Set" is written in a smaller font.A rectangular display box with a light gray background. The text "CLO" is displayed in a large, black, monospace font. Below the text, the word "Set" is written in a smaller font.

## Device Information and Other General Commands

### Show Information about the Device Command (?)

This command prints out basic information about the device. Statuses of the different objects are found with the **STATUS** command, see [Show Status of Subfunctions Command \(STATUS\) on page 86](#).

Syntax: ?<cr>

**Example:**

```
>?  
*** VAISALA OMT300 TRANSMITTER ***  
Device          : OMT364  
SW version      : 1.02  
SNUM            : A1234567  
Calibrated      : 2005-12-24  
Calib. text     : Factory calibration  
ADDR            : 0
```

## Show Information about the Device Overriding POLL Mode Command (??)

This command prints out basic information about the device like the ? command with the exception that ?? overrides addressing in POLL mode. This way a device with an unknown address can be accessed to find out its address.

Syntax: ??<cr>

**Example:**

```
>??  
*** VAISALA OMT300 TRANSMITTER ***  
Device          : OMT364  
SW version      : 1.02  
SNUM            : A1234567  
Calibrated      : 2005-12-24  
Calib. text     : Factory calibration  
ADDR            : 91
```

**NOTE**

There is a delay in the output for command ?? depending on the address assigned to the device.

## Show Measuring Parameters Command (CALCS)

This command prints all the parameter names the device can measure.

Syntax: **CALCS**<cr>

### Example:

```
>calcs
O2          - Filtered O2 results
TGASC       - Gas temperature (celsius)
TGASF       - Gas temperature (fahrenheit)
```

## Show Calibration Information (CINFO)

This command displays information about the last adjustment.

Syntax: **CINFO**<cr>

### Example:

```
Factory calibration:
Calibrated      : 2005-12-24
Calib. text     : Factory calibration

Cal. point 1:
Given oxygen           : 0.00
Gas temperature (C)    : 20.81
Ref path temperature (C): 21.90

Cal. point 2:
Given oxygen           : 21.00
Gas temperature (C)    : 20.81
Ref path temperature (C): 21.90
...
```

## Show Display Board Status Command (DB)

This command shows the status of the display board interface.

Syntax: **DB**<cr>

### Example:

```
*** DISPLAY BOARD (DB) ***
Mode           : NORMAL
State          : NORMAL
Fault HW state : OFF
Display state  : 02
Red led        : OFF
Green led      : SLOW
Relay          : CLOSE
RELAY_MODE     : FAULT_ALARM
LO POINT (%02) : 10.0
HI POINT (%02) : 11.0
```

## List Commands Command (HELP)

Without a parameter this command prints out a list of valid commands with the current password level. Giving a command name as a parameter prints out a more detailed description of the command.

Syntax: **HELP** [command]<cr>

where

command = Command name

### Example:

```
>help
?      Prints information about the device
??     Prints information even in POLL mode
.
.
>
```

## Show Laser Temperature Controller Status Command (LTC)

This command displays the status of the laser temperature controller object and related variables.

Syntax: **LTC**<cr>

### Example:

```
>ltc
*** LASER TEMPERATURE CONTROLLER (LTC) ***
Mode           : ON
State          : TEMP_OK
Set Temp (C)   : 29.074
Temp (C)       : 29.073
Diff (C)       : -0.001
PID Output     : -773
DAC Output     : 29227
```

## Show Output Status Command (OUT)

This command displays the status of the analog output controller object and related variables.

Syntax: **OUT**<cr>

### Example:

```
>out
*** ANALOG OUTPUT (OUT) ***
Mode           : NORMAL
State          : NORMAL
Oxygen (%)     : 0.00
Current (mA)   : 3.00
DAC Output     : 50000

GI             : 1.0000
OI             : 0.0000
NONFATALI (mA) : 3.000
FATALI (mA)    : 2.000
I4             : 1
OUTMAX02 (%)   : 20.000
OUTMIN02 (%)   : 0.000
```

## Show All Modifiable Parameter Values (PARAM)

This command displays the current values of all parameters that can be set by the user.

Syntax: **PARAM**<cr>

### Example:

```
>param
Customer Interface-----
SERI          : 19200 8 NONE 1
ECHO          : ON
SMODE         : STOP
Service Interface-----
SERI          : 115200 8 NONE 1
ECHO          : ON
SMODE         : STOP
Common Serial parameters-----
ADDR          : 0
INTV          : 1 S
FORM          : F0
Analog Output-----
OUTMINO2 (%)  : 0.000
OUTMAXO2 (%)  : 25.000
I4            : 1
NONFATALI (mA) : 3.000
FATALI (mA)   : 3.000
Relay Output-----
RELAY_MODE    : FAULT_ALARM
LO POINT (%02) : 10.0
HI POINT (%02) : 11.0
Measurement parameters-----
INSTALLATION  : Process measurement
PRESSURE(bar) : 1.000
H2O (g/m3)    : 50
CO2 (vol-%)   : 20
```

## Measure Signal Level Command (SIL)

Test signal level. This command compares the laser signal strength to its original strength. The result is displayed as 0 ... 100 % of the original strength. The original strength is the signal level the laser had when the

factory calibration was made. With this command it is possible to measure contamination of the optics.

Syntax: **SIL**<cr>

**Example:**

```
>sil  
Signal level is 100% compared to signal level at factory
```

## Signal Level Display Function (Sil)

When the signal level display function **Sil** is selected the laser signal strength is compared to its original strength (displayed as 0 ... 100 % of the original strength). The original strength is the signal level the laser had when the factory calibration was made. With this function it is possible to measure contamination of the optics.

A rectangular digital display with a light gray background and a thin black border. The characters 'SIL' are shown in a large, black, monospaced font.

A rectangular digital display with a light gray background and a thin black border. The characters '98%' are shown in a large, black, monospaced font.

## Show Statistical Information Command (STATS)

This command displays statistical information.

Syntax: **STATS**<cr>

**Example:**

```
>stats
All cleared      : 2006-01-18 13:40:04
Uptime (h)      : 140
Resets          : 7
O2 max          : 21.06
O2 min          : 4.91
Tg max          : 29.71
Tg min          : 23.39
Ti max          : 32.53
Ti min          : 24.55
```

## Show Status of Subfunctions Command (STATUS)

This command displays modes and status of all sub functions.

Syntax: **STATUS**<cr>

**Example:**

```
>status

Sub function modes and states:

*** LASER TEMPERATURE CONTROLLER (LTC) ***
Mode          : ON
State         : TEMP_OK
*** OXYGEN MEASUREMENT (MEA) ***
Mode          : MODE2
State         : PEAK_LOCKED
Run Time Func. : OFF
*** ANALOG OUTPUT (OUT) ***
Mode          : NORMAL
State         : NORMAL
*** ERROR CONTROL (ERR) ***
Mode          : ON
State         : NO ERRORS
*** CUSTOMER INTERFACE (SCI2) ***:
Mode          : STOP
*** SERVICE INTERFACE (SCI1) ***:
Mode          : STOP
*** DISPLAY BOARD (DB) ***
Mode          : NORMAL
State         : NORMAL
>
```

## Show Product Name and Software Version Command (VERS)

This command prints out the device name and the software version.

Syntax: **VERS**<cr>

### Example:

```
>vers  
OMT300 / 1.02
```

## Memory Handling

### Save Parameters Command (SAVE)

**NOTE**

Remember to use the **SAVE** command whenever you make any changes to any of the parameters, otherwise the changes might be lost.

This command saves the parameters from RAM to EEPROM memory.

Syntax: **SAVE**<cr>

### Example:

```
>save  
EEPROM (basic) saved successfully  
EEPROM (op) saved successfully  
EEPROM (op_log1) saved successfully  
EEPROM (op_log2) saved successfully
```

## Resetting the Transmitter

### Reset Command (RESET)

This command resets the transmitter. This command has exactly the same effect as toggling power to the transmitter.

Syntax: **RESET**<cr>

**Example:**

```
>reset  
Resetting...
```

```
OMT300 - Version STD 1.02  
Vaisala Oyj, 2004-2005  
...
```

### Reset Function (Off)

When the reset function **Off** is selected the transmitter stops all operations and performs a reset. To reset the transmitter, select function **Off** from the menu and press **Ent**. The text "OFF" starts to blink on the display. Press **Ent** a second time to confirm the operation. The text "RESE" is displayed and the transmitter resets. New measurement starts after the self-test is completed and the oxygen absorption line is found.



OFF



RESE

## CHAPTER 6

# SETTING ENVIRONMENTAL PARAMETERS

## Environmental Parameter Compensations

The oxygen measurement of OMT364 is somewhat affected by the temperature, pressure and background gas of the measuring environment.

Because of these phenomena, OMT364 has built-in compensations for the temperature and pressure of the operating environment as well as for the water and CO<sub>2</sub> content of the background gas. To achieve the most accurate measurement, the compensations should be enabled. The compensated output corresponds to "% O<sub>2</sub>" in the actual environment (T, P, humidity, and CO<sub>2</sub>). Please see [Table 14 on page 151](#) for measurement specifications and the magnitude of the effect temperature, pressure and background gas have on the measurement result.

The temperature compensation of OMT364 is based on two integrated temperature sensors. The temperature compensation feature is automatic and always enabled.

Pressure, humidity and CO<sub>2</sub> compensations require that the values of the environmental parameters be set by the user if they are different from the factory set defaults (when using the factory defaults, the other compensations are essentially disabled). The default environmental parameters of OMT364 are:

- Pressure 1013.25 hPa
- Water content 0 g/m<sup>3</sup>H<sub>2</sub>O
- Relative carbon dioxide concentration 0 vol-% CO<sub>2</sub>

## Operating Temperature

The device measures both its internal temperature and the temperature of the process gas and these are used to compensate the oxygen measurement reading. External temperature settings cannot be used. Uncompensated, the error caused by the temperature dependency is of "percentage of reading"-type.

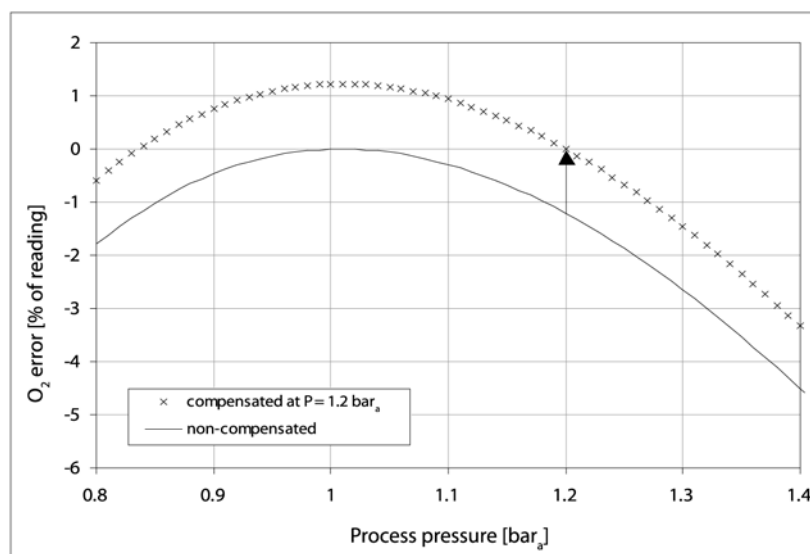
The accuracy of the temperature measurement probe measuring the process gas temperature is somewhat affected by the heat conducted by the transmitter electronics housing when there is a significant temperature difference between the process and the location of the transmitter housing. In these kind of conditions, the reading of the temperature probe that is used in the compensation is not an entirely accurate representation of the process gas temperature. For more information on this phenomenon, see [Selecting the Location on page 27](#).

## Operating Pressure

Due to the measurement algorithm used in the transmitter, the pressure dependency of the measurement is small. This is characteristic of the measurement principle based on the TDLAS method. However, a small pressure dependency still exists because the shape of the oxygen absorption lines is pressure dependent. The error caused by the pressure dependency is of "percentage of reading"-type.

The operating pressure discussed in this section refers to the process pressure, which is the pressure of the gas under measurement. The measurement probe is installed into this pressure. The pressure outside the process, where the transmitter housing is installed, should be normal atmospheric pressure. For further information, see [OMT364 for In-Line and Sampling Cell Mounting on page 18](#).

The typical effect of the error as a function of process pressure is shown in the non-compensated graph of [Figure 22 on page 91](#). The shape of the error curve resembles a parabola and the magnitude of the error is smallest around normal atmospheric pressure.



**Figure 22** Effect of Process Pressure Compensation

Even though the pressure dependency properties of OMT364 are inherently good, you can choose to further compensate the measurement result by setting the average pressure of the operating conditions to the device. This can be done either using the local display and keypad or through the serial line. For more information about the commands, see sections [Set \(Average\) Process Pressure Function \(App\)](#) on page 93, [Show/Set Pressure for Compensation Command \(PRES\)](#) on page 92 and [Set Pressure for Compensation Command \(XPRES\)](#) on page 93.

Setting the value of the average process pressure compensates the measurement error caused by the pressure dependency close to zero in the immediate vicinity of pressure value in question.

[Figure 22 on page 91](#) illustrates the effect of pressure compensation in the case where the average process pressure value is set to 1.2 bar<sub>a</sub>. The original error of approximately 1 % of reading at 1.2 bar<sub>a</sub> is compensated down to zero, but pressure dependency still exists with other values of process pressure.

Specifically you should note that setting the pressure compensation does not shift the parabola-like curve of [Figure 22 on page 91](#) along the x-axis. That is, even with the compensation enabled, changes in pressure from the compensation value have a more significant effect than at normal atmospheric pressure.

**NOTE**

If the pressure compensation is enabled, and then the transmitter is removed from the process to be calibrated and adjusted somewhere else, you have to set the pressure according to the adjustment environment. The pressure setting then has to be changed back to represent the operating conditions when the transmitter is reinstalled to the process.

**NOTE**

To disable the pressure compensation, set the average process pressure value to the standard atmospheric pressure 1.013 bar<sub>a</sub>. With this setting the magnitude of the pressure compensation is zero.

## Show/Set Pressure for Compensation Command (PRES)

Set pressure for compensation. The accepted range is 0.800 ... 1.400 bar<sub>a</sub>. This pressure setting will be stored in EEPROM when the **SAVE** command is issued after making the setting.

Syntax: **PRES** [pressure]<cr>

where

pressure = Pressure of measured gas (bar<sub>a</sub>)

### Example:

Remember to issue the **SAVE** command, otherwise the pressure setting is lost after next reset.

```
>pres 1.300
PRESSURE(bar) : 1.300      ?
>save
EEPROM (basic) saved successfully
EEPROM (op) saved successfully
EEPROM (op_log1) saved successfully
EEPROM (op_log2) saved successfully
>
```

## Set Pressure for Compensation Command (XPRES)

Set pressure for compensation. The accepted range is 0.800 ... 1.400 bar<sub>a</sub>. This pressure setting will NOT be stored in EEPROM by **SAVE** command. This command is useful for a system where pressure is measured continuously and the pressure value is sent to the oxygen transmitter.

Syntax: **XPRES** [pressure]<cr>

where

pressure = Pressure setting (bar<sub>a</sub>)

### Example:

```
>xpres 1.300  
PRESSURE(bar) : 1.300 ?
```

## Set (Average) Process Pressure Function (App)

When the set (average) process pressure function **App** has been selected 1.013 bar<sub>a</sub> is displayed as a default value (first time). The pressure value is changed by using the **Up/Dn** keys. The accepted range is 0.800 ... 1.400 bar<sub>a</sub>. The new pressure setting is accepted by pressing **Ent**. The text "PASS" is displayed when the setting is in the accepted range.



# Background Gas Effects

## General Information About Background Gas Effects

Individual absorption line widths of O<sub>2</sub> gas are sensitive to intermolecular collisions between O<sub>2</sub> and background gas molecules. This has an effect on the O<sub>2</sub> reading of the transmitter. The magnitude of this effect depends on the amount and type of background molecules.

The factory calibration of OMT364 is carried out using dry N<sub>2</sub> and O<sub>2</sub> mixtures. Humidity and CO<sub>2</sub> concentration of the calibration gases are 0 %. This means that all other background gases except dry N<sub>2</sub> result in a small "percentage of reading"-type of error in the O<sub>2</sub> measurement.

Carbon dioxide and water vapor are the most common gases whose effects on the measurement of oxygen have to be compensated for. OMT364 has built-in compensations for the (average) water and CO<sub>2</sub> content of the background gas. The compensation is based on the user manually setting the values for the water and CO<sub>2</sub> content of the background gas to the device. Water content is expressed in terms of absolute humidity in g/m<sup>3</sup> H<sub>2</sub>O. See [Appendix B, Humidity Conversion Table, on page 157](#) for converting relative humidity values into absolute humidity values when temperature is known. Equations for the conversions are given in [Water Content of Background Gas on page 95](#).

**NOTE**

If the humidity and CO<sub>2</sub> compensations are enabled, and then the transmitter is removed from the process to be calibrated and adjusted somewhere else, you have to set the water and CO<sub>2</sub> content according to the adjustment environment. These settings then have to be changed back to represent those of the operating conditions when the transmitter is reinstalled to the process.

**NOTE**

The humidity and CO<sub>2</sub> compensations are disabled by setting the water and CO<sub>2</sub> content of the background gas as zero (factory default).

## Water Content of Background Gas

Since relative humidity is strongly dependent on temperature, the dependence on water content is expressed in terms of absolute humidity,  $\text{g/m}^3\text{H}_2\text{O}$ . The absolute humidity in  $\text{g/m}^3\text{H}_2\text{O}$  can be calculated from relative humidity and gas temperature using the following equations:

$$H_2O (\text{g/m}^3) = C \times P_W / T$$

where

$$\begin{aligned} T &= \text{Gas temperature in K } (= 273.15 + T \text{ } ^\circ\text{C}) \\ P_W &= \text{Water vapor pressure in hPa} \\ C &= 216.679 \text{ gK/J} \end{aligned}$$

$$P_W = P_{WS} \times RH(\%) / 100$$

where

$$RH(\%) = \text{Relative humidity, and } P_{WS} \text{ is the water saturation vapor pressure, or}$$

$$P_{WS} = 1000 \times 10^{28.59051 - 8.2 \log T + 0.0024804T - 3142/T}$$

where

$$T = \text{As given above}$$

### Example:

The gas temperature is  $40^\circ\text{C}$  and the relative humidity is 90%.

The absolute humidity in  $\text{g/m}^3$  is calculated from the above data as follows:

First, calculate the water vapor pressure  $P_W$ :

$$P_W \text{ (hPa)} = P_{WS} (40 \text{ }^\circ\text{C}) \times 90/100 = 66.5$$

Then, use this result to calculate the absolute humidity:

$$\text{H}_2\text{O (g/m}^3\text{)} = 216.679 \times 66.5 / (273.15 + 40 \text{ }^\circ\text{C}) = 46.0$$

[Table 8 on page 96](#) lists some conversions from T and RH to absolute humidity for quick reference use. The conversion table also lists the effect of these conditions on the O<sub>2</sub> reading of the device.

**Table 8 Conversion Table from T and RH to Absolute Humidity and the Effect of Humidity on Transmitter Reading**

			Effect of humidity on O <sub>2</sub> reading (% reading)	
T °C	%RH	g/m <sup>3</sup> H <sub>2</sub> O	Dependency	Dilution
-20	50	0.5	0.0	-0.1
-20	90	1.0	0.0	-0.1
0	50	2.4	-0.1	-0.3
0	90	4.4	-0.2	-0.5
25	50	11.5	-0.4	-1.6
25	90	20.7	-0.7	-2.8
40	50	25.6	-0.9	-3.6
40	90	46.0	-1.6	-6.6
60	50	64.9	-2.1	-9.8
60	90	116.8	-3.6	-17.7
80	50	145.5	-4.2	-23.4
80	90	262.0	-6.3	-42.1

When looking at the numbers in [Table 8 on page 96](#), it is clear that the water content of the background gas affects the oxygen measurement result in two ways:

1. The water molecules contained by the background gas displace a certain amount of oxygen molecules.
2. The collisions between the water and oxygen molecules affect the shape of the oxygen absorption lines.

The first effect is the dilution of the oxygen concentration of the measured gas (water displaces oxygen so there is a lower concentration of oxygen in the measured gas). This is not, and should not be

compensated for in the measurement. Only the second effect is due to the measurement principle, and this can be compensated for.

The dependency due to the measurement principle is given in the 4th column of [Table 8 on page 96](#). This is compensated for and is eliminated, when the water content of the measured gas is entered in the transmitter memory.

The 5th column of [Table 8 on page 96](#) shows the effect of dilution. This effect is much more powerful than the one due to the measurement principle. It remains even if the water content is compensated for, because it is the actual decrease of oxygen content in the measured gas due to water displacing oxygen in the gas mixture.

## Set Water Content for Compensation Command (H2O)

Set water content for compensation. The setting will be stored in EEPROM by **SAVE** command. The accepted range is 0 ... 600 g/m<sup>3</sup> H<sub>2</sub>O.

Syntax: **H2O** [water]<cr>

where

water = Water content in measured gas (g/m<sup>3</sup> H<sub>2</sub>O)

### Example:

```
>H2O 100
WATER (g/m3) : 100      ?
```

## Set (Average) Water Content Function (H2O)

When the set (average) water content function **H2O** has been selected 000 (g/m<sup>3</sup> H<sub>2</sub>O) is displayed as a default value (first time). The water content value is changed by using the **Up/Dn** keys. The accepted range is 0 ... 600 g/m<sup>3</sup> H<sub>2</sub>O. The new water content setting is accepted by pressing **Ent**. The text "PASS" is displayed when the setting is in the accepted range.



## CO<sub>2</sub> Concentration of Background Gas

The effect of CO<sub>2</sub> on the O<sub>2</sub> reading is so small that in most circumstances, there is no need to make the CO<sub>2</sub> compensation. The CO<sub>2</sub> dependence is expressed in terms of relative CO<sub>2</sub> concentration (vol-% CO<sub>2</sub>).

**NOTE**

The gas pressure value must be given in CO<sub>2</sub> compensations.

## Set Carbon Dioxide Content for Compensation Command (CO<sub>2</sub>)

Set CO<sub>2</sub> concentration for compensation. The setting will be stored in EEPROM by **SAVE** command. The accepted range is 0 ... 100 vol-% CO<sub>2</sub>.

Syntax: **CO2** [carbon dioxide]<cr>

where

carbon dioxide = CO<sub>2</sub> concentration in measured gas (vol-% CO<sub>2</sub>)

**Example:**

```
>co2 10
CO2(%) : 10 ?
```

### Set (Average) Carbon Dioxide Content Function (CO2)

When the set (average) carbon dioxide content function **CO2** has been selected 000 % CO<sub>2</sub> is displayed as a default value (first time). The CO<sub>2</sub> concentration value is changed by using the **Up/Dn** keys. The accepted range is 0 ... 100 vol-% CO<sub>2</sub>. The new CO<sub>2</sub> content setting is accepted by pressing **Ent**. The text "PASS" is displayed when the setting is in the accepted range.



## Setting Several/All Environmental Parameters with Single Command (ENV)

This command sets several or all environmental parameters. After familiarizing yourself with the effect environmental parameters have on oxygen measurement, the **ENV** command is a convenient way of setting several or all of the available environmental parameters to the transmitter memory at once.

Syntax: **ENV** [pressure] [water] [carbon dioxide]<cr>

where

pressure = Pressure setting (bar<sub>a</sub>)

water = Water content in measured gas (g/m<sup>3</sup> H<sub>2</sub>O)

carbon dioxide = CO<sub>2</sub> concentration in measured gas (vol-% CO<sub>2</sub>)

### Examples:

ENV command without parameters displays the current environmental parameter values and requests a new one (hit Enter to accept the current setting):

```
>env
PRESSURE(bar) : 1.013 ?
H2O (g/m3)    : 0 ?
CO2 (vol-%)   : 0 ?
>
```

Set pressure 1.000 bar<sub>a</sub>, water content 50 g/m<sup>3</sup> and CO<sub>2</sub> content 20 vol-% CO<sub>2</sub>:

```
>env 1 50 20
PRESSURE(bar) : 1.000
H2O (g/m3)    : 50
CO2 (vol-%)   : 20
>
```

## CHAPTER 7

# CALIBRATION AND ADJUSTMENT (IN-LINE AND SAMPLING CELL VERSIONS OF OMT364)

In this User's Guide the term calibration refers to comparing the device's reading against a reference concentration. Adjustment refers to changing the device's reading to correspond to the reference concentration.

Read the instructions through carefully before making any adjustments or parameter changes. Vaisala accepts no responsibility for parameter or settings changes nor adjustments made by the user. When you require technical support or assistance, please contact Vaisala Technical Support (see [Technical Support on page 149](#)).

### **CAUTION**

The calibration and adjustment of the in-line and sampling cell versions are slightly different than calibration and adjustment of the ambient gas measurement version. Make sure you are reading the correct chapter. Ambient gas measurement version calibration and adjustment is covered in chapter 8.

# Hardware Arrangements for Calibration and Adjustment

## Getting Started

Calibration can be done simply by observing the measurement reading of the transmitter. Before calibration or adjustment the transmitter should be on for at least 15 minutes. Adjustment requires user access to serial line or local keypad interface:

1. Open the back cover of the transmitter with a 4 mm hex socket (Allen) key.
2. If you wish to use serial communication, connect the serial line cable and open the terminal program with valid serial communication settings (default settings are 19200/8/N/1). After the self test is completed, if necessary, stop printing oxygen measurement results with command **S** (or by pressing **Esc**).
3. Connect the appropriate gas arrangements (see [Gas Feed Setup for Calibration and Adjustment on page 102](#)), and follow proper calibration or adjustment procedure (see [Calibration on page 107](#) and [Adjustment on page 109](#)).

## Gas Feed Setup for Calibration and Adjustment

The gas feed setup for calibration and adjustment for the in-line and sampling versions of the OMT364 can be done in two different ways: by using ambient air or by using bottled gas and the calibration chamber. These two ways are described in this section.

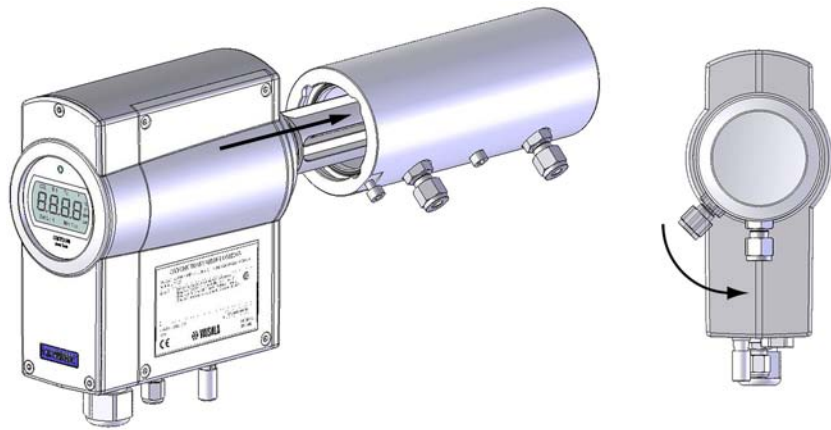
### Using Ambient Air

Ambient air may be used for calibration purposes. In this case, it is sufficient to expose the transmitter to ambient conditions. See [Using Ambient Air on page 107](#) for calibration procedures.

## Using Bottled Gas and Calibration Chamber

### Setup

Insert probe into the calibration chamber. Push it slightly down and turn it clockwise 45°. If you have problems while inserting the probe, check that the O-ring is properly in its groove. The calibration gas inlets are equipped with 1/8" NPT gas fittings for  $\varnothing$  6 mm tubing. Let the gas flow freely out, so that there is no overpressure in the chamber.



**Figure 23** Attaching OMT364 Probe into Calibration Chamber

### Calibration or Adjustment in Process

#### NOTE

Adjustment in process requires a suitably configured transmitter with the optional calibration gas inlet. PTFE filter must also be used.

This adjustment is done without removing the transmitter from the process. The reference gas is fed through the optional calibration gas inlet in the bottom of the transmitter electronics enclosure.

Typical adjustment accuracy is within  $\pm 0.2$  %O<sub>2</sub> when using a reference gas flow of 5 ... 9 l/min. With flow rates in this range, the effect of process gas velocity (in the range 0 ... 20 m/s) on adjustment accuracy is negligible.

With flow rates well below 5 l/min calibration uncertainty grows and high process gas velocity has an adverse effect on adjustment accuracy. This is because diffusion through the oxygen measurement probe filter

causes a small error in reference gas concentration. For example, with a reference gas flow rate of 2 l/min and process gas velocity of 20 m/s, adjustment accuracy is significantly worse than  $\pm 0.2\% \text{O}_2$ .

The amount of unwanted counter diffusion through the filter depends on the  $\text{O}_2$  concentration difference between the reference gas and the process gas. For example, if you are using 100 % $\text{N}_2$  as a reference and the process gas has 2 % $\text{O}_2$ , the result is better than if the process gas had 21 % $\text{O}_2$ .

For best adjustment results, use high enough reference gas flow rates. With low flow rates, good adjustment accuracy is generally achieved only with near zero process gas velocities.

### Connections and Systems

The OMT364 calibration gas inlet is equipped with a Swagelok gas fitting for tubes with 6 mm outer diameter. To allow flow only from the calibration gas inlet to the process and prevent flow from the process to the calibration gas inlet, a back pressure valve with approximately 1.7 bar cracking pressure is utilized. However, after some idle time, the initial cracking pressure can be higher than the specified 1.7 bar. Therefore, the use of a flow-control device such as a rotameter is recommended to detect the calibration gas flow. After the back pressure valve cracks open, the rotameter can then be used to adjust the gas flow to the desired setting.

### Preparations for Adjustment

**CAUTION**

Make sure the process can withstand the reference gas to be used, since out flowing gas is fed directly into the process.

### Connecting the Gas

1. Remove the plug from the optional gas inlet of OMT364.
2. Fit the reference gas tube to the inlet using a 14 mm wrench, be careful not to overtighten the inlet.

**NOTE**

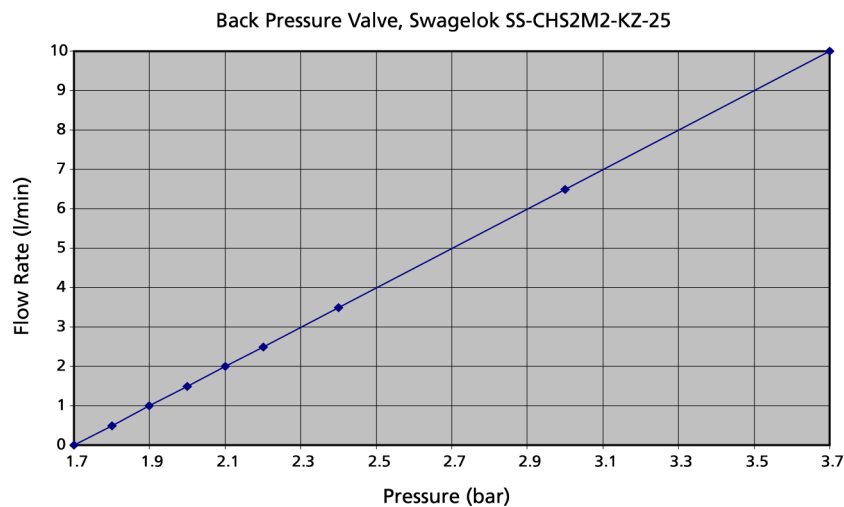
Although the back pressure valve prevents process gas from escaping, you can further ensure this by using the plug in the optional gas inlet of OMT364 to when reference gas is not connected. This also prevents dust and dirt buildup in the gas inlet.

### Adjusting Gas Flow

1. To avoid rapid pressure shocks, open the gas container valve smoothly.
2. To allow for a nonrestricted flow, open the flow-control device (for example, a rotameter) completely.
3. Slowly increase the pressure setting of the regulator until gas flow can be detected with the rotameter (the back pressure valve of the Swagelok connector has approximately 1.7 bar cracking pressure).
4. Using the rotameter, adjust the flow rate to a desired setting.

For best adjustment accuracy, use a flow rate of at least 5 l/min and up to 9 l/min to minimize the unwanted mixing of process and reference gases. For 9 l/min reference gas flow, a pressure of approximately 3.5 bar<sub>a</sub> is needed. For more information about adjustment accuracy and flow rates, see [Calibration or Adjustment in Process on page 103](#).

In case you do not have access to a flow-control device, you can refer to [Figure 24 on page 106](#) for information on the flow rate in relation to reference gas pressure given by the back pressure valve of the optional calibration gas inlet of OMT364.



**Figure 24** Flow Rate vs. Pressure, Back Pressure Valve Swagelok SS-CHSM2-KZ-25

### Information on Calibration Gases

The factory calibration of OMT364 is carried out using dry N<sub>2</sub> and O<sub>2</sub> mixtures. Humidity and CO<sub>2</sub> concentration of the calibration gases are 0 %. Nitrogen mixture gases are recommended for calibration and adjustment of OMT364. For calibration and adjustment of OMT364, gas flow rate of about 0.5 l/min is adequate, but for a faster response during calibration and adjustment, use higher flow rates. Note however, that with high flow rates, the gas pressure is higher, and you need to use large enough tubing for the outgoing gas.

**NOTE**

Allow enough time for the gas concentration to stabilize when doing calibrations/adjustments.

## Calibration

### Using Ambient Air

Normal ambient air provides a convenient way to calibrate the OMT364, because the oxygen concentration of dry ambient air is constant 20.95 %O<sub>2</sub>.

Calibration with ambient air is done simply by exposing the transmitter to ambient conditions and observing the O<sub>2</sub> reading. When calibrating with dry ambient air, the oxygen reading should be 21.0 %O<sub>2</sub> ±0.2 %O<sub>2</sub>. In practice, ambient air is seldom dry and humidity correction is needed. The chart in [Figure 25 on page 107](#) shows the expected calibration reading with ambient air as function of of temperature (T) and relative humidity (%RH).

The oxygen readings (in units of %O<sub>2</sub>) when measuring gas concentration of 20.95%O<sub>2</sub> with alternating humidity, are given in the chart below. It gives an example of readings when measuring humid gases with no RH corrections given to the OMT364 transmitter (that is, RH is set as 0%RH). Both gas dilution effect and RH dependency effect are included in the chart.

T [C]	Relative Humidity [%RH]										
	0	10	20	30	40	50	60	70	80	90	100
0	21.0	21.0	21.0	21.0	20.9	20.9	20.9	20.9	20.9	20.9	20.8
5	21.0	21.0	21.0	20.9	20.9	20.9	20.9	20.8	20.8	20.8	20.8
10	21.0	21.0	20.9	20.9	20.9	20.8	20.8	20.8	20.7	20.7	20.7
15	21.0	21.0	20.9	20.9	20.8	20.8	20.7	20.7	20.6	20.6	20.6
20	21.0	20.9	20.9	20.8	20.8	20.7	20.6	20.6	20.5	20.4	20.4
25	21.0	20.9	20.8	20.8	20.7	20.6	20.5	20.4	20.3	20.3	20.2
30	21.0	20.9	20.8	20.7	20.6	20.4	20.3	20.2	20.1	20.0	19.9
35	21.0	20.9	20.7	20.6	20.4	20.3	20.1	20.0	19.8	19.7	19.6
40	21.0	20.8	20.6	20.4	20.2	20.1	19.9	19.7	19.5	19.3	19.1
45	21.0	20.8	20.5	20.3	20.0	19.8	19.5	19.3	19.1	18.8	18.6
50	21.0	20.7	20.4	20.1	19.7	19.4	19.1	18.8	18.5	18.2	17.9
55	21.0	20.6	20.2	19.8	19.4	19.0	18.6	18.3	17.9	17.5	17.2
60	21.0	20.5	20.0	19.5	19.0	18.5	18.1	17.6	17.1	16.7	16.2
65	21.0	20.4	19.7	19.1	18.5	17.9	17.3	16.8	16.2	15.6	15.1
70	21.0	20.2	19.4	18.7	17.9	17.2	16.5	15.8	15.1	14.4	13.8
75	21.0	20.0	19.1	18.2	17.3	16.4	15.5	14.7	13.8	13.0	12.2
80	21.0	19.8	18.7	17.5	16.5	15.4	14.4	13.4	12.4	11.4	10.4

**Figure 25 Oxygen Readings in Relative Humidity**

## Using Calibration Gases

For simple calibration of the in-line and sampling versions of OMT364, Vaisala recommends using normal ambient air, see [Using Ambient Air on page 107](#).

If a calibration gas (like synthetic air or precision O<sub>2</sub> concentration gas) is used, refer to [Hardware Arrangements for Calibration and Adjustment on page 102](#) for arranging the setup.

## Calibration Procedures

### Lock Outputs for Calibration Command (ADJUST)

This command locks all the outputs to their current values or frees them from the lock. This command can be used for checking the calibration against a known reference gas, or during on-line adjustment, so process control is not disturbed by the changing readings.

Syntax: **ADJUST** [on/off]<cr>

#### Example:

```
>adjust on
Outputs (analog, relay, POLL/Run and MT300) frozen
>
```

### Calibration Check Function (Cal.C)

When the calibration check function **Cal.C** has been selected, you can check the calibration using a reference gas. At the same time the analog output is frozen to the state preceding the time the calibration check operation was activated. The calibration check mode is stopped by pressing **Back**.



## Adjustment

**NOTE**

Adjustment features are password protected. After entering the password, it expires in 30 minutes. If the password expires while a password protected function is running, the function is still completed. To access password protected features after the password has expired, re-enter the password.

**NOTE**

If there are any errors active in the device, adjustment might fail at any point during the procedure. Therefore it is recommended that you clear all errors before attempting any adjustments. For instructions on clearing nonfatal errors and warnings, see section [Error Display on page 147](#).

**NOTE**

Make sure that environmental parameters are set according to the adjustment environment before attempting any adjustments. Set the pressure, humidity, and CO<sub>2</sub> concentration values of the calibration gas. Typically the humidity of the calibration gases is 0 g/m<sup>3</sup>H<sub>2</sub>O. CO<sub>2</sub> concentration of nitrogen mixture gases is usually 0 vol-% CO<sub>2</sub>.

After making the adjustment, set the environmental parameters back to represent the values of the process gas. For more information about environmental parameter compensations, see [Environmental Parameter Compensations on page 89](#).

## Possible Adjustments

The following adjustments are available to the customer:

- One-point adjustment using the serial line
- One-point adjustment using the Local Interface
- Two-point adjustment using the serial line
- Two-point adjustment using the Local Interface
- Restoring the factory calibration

One-point adjustment changes either the measurement gain or offset value. If the given reference gas O<sub>2</sub> concentration is >10.5 %O<sub>2</sub>, the result of one-point adjustment is a new gain value, otherwise the result is a new offset value. The result of two-point adjustment is always both new gain and offset values.

## One-Point Adjustment Using Serial Line

This command is used to make a one-point adjustment.

### One-Point Adjustment Command (COXY1) and Procedure Using Serial Line

As a result of this adjustment, new gain or offset parameter value (depending on the reference concentration used) is calculated and set.

1. Type **PASS "XXXX"** (the password) and press **Enter** (on your computer keyboard).
2. Type **ADJUST ON**, press **Enter**.

This command locks all the outputs to their current values. This command should be used during on-line adjustment, so process control is not disturbed by the changing readings. If the device is removed from the process or disconnected from process controls during adjustment, this step can be omitted.

```
>adjust on
```

```
Outputs (analog, relay, POLL/Run and MT300) frozen
```

3. If the adjustment conditions (gas pressure, humidity, and CO<sub>2</sub> concentration) are different from the operating conditions of the transmitter, you have to set the environmental parameters of the adjustment environment to the transmitter for the duration of the adjustment. These settings must then be changed back to represent the process conditions when the transmitter is reinstalled in its operating environment. For more information on setting environmental parameters to OMT364, see [Setting Several/All Environmental Parameters with Single Command \(ENV\)](#) on page 100.
4. Type the one-point adjustment command **COXY1**, press **Enter**.
5. Connect the gas inflow in place and start the gas flow.
6. The calibration starts. At this stage, you may opt to use the following commands:
  - Enter** - The most recent measurement result is printed or continuous printing is stopped.
  - R + Enter** - Measurement results are printed continuously at approximately one second intervals. Press **Enter** again to stop printing results.
  - Esc** - Abort the calibration.
7. Observe when the reading has stabilized. Type the reference gas concentration and press **Enter**. New gain or offset parameter value is now calculated and displayed. The output after giving the **COXY1** command:

```

>coxy1
Customer calibration
Current condition/settings:
Pressure (bar)           : 1.013
H2O (g/m3)              : 0
CO2 (vol-%)             : 0
Gas temperature (C)     : 23.64
Internal temperature (C): 24.84
If parameters are not correct, cancel calibration by
ESC and change parameters.
Connect ref gas to cuvette.
O2 (%): 20.52 Ref ?
O2 (%): 20.51 Ref ?
O2 (%): 20.51 Ref ?
O2 (%): 20.51 Ref ? 20.50
Calibration data:
Pressure setting (bar)  : 1.013

```

```
Measured oxygen      : 20.51
Given oxygen        : 20.50
Gas temperature (C)  : 23.65
Ref path temperature (C): 24.85
New Gain           : 1.000
Calibration ready - remember SAVE command
>
```

8. Now type **SAVE**, press **Enter**. The new values are stored to EEPROM.

```
>save
EEPROM (basic) saved successfully
EEPROM (op) saved successfully
EEPROM (op_log1) saved successfully
EEPROM (op_log2) saved successfully
```

9. Type **ADJUST OFF**, press **Enter**. The adjustment is done and the outputs return to displaying the measurement results.

```
>adjust off
Outputs to normal state
```

## One-Point Adjustment Using Local Interface

### One-Point Adjustment Function (CAL1)

When the one-point calibration function **Cal1** has been selected, the analog output is frozen.

Attach the reference gas and perform the adjustment according to instructions in [Chapter 7, Calibration and Adjustment \(In-Line and Sampling Cell Versions of OMT364\)](#), on page 101, mainly in sections [Connections and Systems](#) on page 104, [Connecting the Gas](#) on page 104 and [One-Point Adjustment Procedure Using Local Interface](#) on page 113.

Adjustment can be interrupted at any time by pressing the **Back** key.



## One-Point Adjustment Procedure Using Local Interface

Depending on the reference concentration used, this adjustment changes the gain or offset parameter value. At oxygen concentrations below 10.5 %O<sub>2</sub>, the offset value is changed, and above 10.5 %O<sub>2</sub> the gain value is changed.

1. Select **Pass** from the menu and give the password. After the password is given, more options appear in the menu.
2. If the adjustment conditions (gas pressure, humidity, and CO<sub>2</sub> concentration) are different from the operating conditions of the transmitter, you have to set the environmental parameters of the adjustment environment to the transmitter for the duration of the adjustment. These settings must then be changed back to represent the process conditions when the transmitter is reinstalled in its operating environment. For more information on setting environmental parameters to OMT364, see [Chapter 6, Setting Environmental Parameters, on page 89](#).
3. Select **Cal1** from the menu.

This starts the adjustment mode provided there are no fatal errors active in the device. The adjustment mode freezes the analog output and the RUN/POLL modes to their current states.

4. Connect the reference gas.
5. The display shows "Set 20.0 %". Use the **Up/Dn** keys to set the correct concentration of the reference gas (in 0.1 % steps). Accept the reading by pressing **Ent**. Please note that it is enough that the measured value is constant. The value itself is incorrect, because the adjustment is in progress.

6. The device switches to displaying the settling concentration reading. When the reading has stabilized, press **Ent** again. If the adjustment has been successful, the text "PASS" is displayed.
7. The device now calculates the new gain or offset settings and starts displaying the normal measurement result. At this point either accept the adjustment by pressing **Ent** or cancel everything by pressing **Back**.

The displays return to displaying the measurement results.

## Two-Point Adjustment Using Serial Line

This is the two-point adjustment command.

### Two-Point Adjustment Command (COXY2) and Procedure Using Serial Line

As a result of this adjustment, new gain and offset parameter values are calculated and set. The two-point adjustment procedure is conducted by using one gas for adjusting the low end of the measurement range and another gas for adjusting the high end of the measurement range. These can be, for example pure nitrogen (0.0 %O<sub>2</sub>) and an N<sub>2</sub>/O<sub>2</sub> mixture (for example, 21 %O<sub>2</sub>). The minimum difference between the two reference gas concentrations in two-point adjustment should be at least 4 %O<sub>2</sub>. It does not matter which gas you use first, the low-end or the high-end reference.

1. Type **PASS "XXXX"** (the password) and press **Enter** (on your computer keyboard).
2. Type **ADJUST ON**, press **Enter**.

This command locks all the outputs to their current values. This command should be used during on-line adjustment, so process control is not disturbed by the changing readings. If the device is removed from the process or disconnected from process controls during adjustment, this step can be omitted.

```
>adjust on
```

```
Outputs (analog, relay, POLL/Run and MT300) frozen
```

3. If the adjustment conditions (gas pressure, humidity, and CO<sub>2</sub> concentration) are different from the operating conditions of the transmitter, you have to set the environmental parameters of the adjustment environment to the transmitter for the duration of the adjustment. These settings must then be changed back to represent the process conditions when the transmitter is reinstalled in its operating environment. For more information on setting environmental parameters to OMT364, see [Chapter 6, Setting Environmental Parameters, on page 89](#).
4. Type the two-point adjustment command **COXY2**, press **Enter**.
5. Connect the gas inflow in place and start the gas flow.
6. The calibration starts. At this stage, you may opt to use the following commands:

**Enter** - The most recent measurement result is printed or continuous printing is stopped.

**R + Enter** - Measurement results are printed continuously at approximately one second intervals. Press **Enter** again to stop printing results.

**Esc** - Abort the calibration.

7. Observe when the reading has stabilized. Type the gas concentration for the first reference and press **Enter**. The output after giving the **COXY2** command:

```
>coxy2
Customer calibration
Current condition/settings:
Pressure (bar)           : 1.013
H2O (g/m3)              : 0
CO2 (vol-%)             : 0
Gas temperature (C)     : 23.66
Internal temperature (C): 24.85
If parameters are not correct, cancel calibration by
ESC and change parameters.
Connect ref gas #1 to cuvette.
O2 (%): 20.99 Ref1 ?
O2 (%): 20.99 Ref1 ?
O2 (%): 20.99 Ref1 ?
O2 (%): 20.99 Ref1 ? 21
Connect ref gas #2 to cuvette
```

8. At this point the second reference gas flow is started. Observe when the reading has stabilized. Type the gas concentration for the

second reference and press **Enter**. New gain and offset parameter values are now calculated and displayed.

The output:

```
O2 (%): 10.05 Ref2 ?
O2 (%): 10.05 Ref2 ?
O2 (%): 10.05 Ref2 ?
O2 (%): 10.05 Ref2 ? 10
Calibration data:
Pressure setting (bar) : 1.013
Point #1
Measured oxygen      : 20.99
Given oxygen        : 21.00
Gas temperature (C) : 23.65
Ref path temperature (C): 24.84
Point #2
Measured oxygen      : 10.05
Given oxygen        : 10.00
Gas temperature (C) : 23.66
Ref path temperature (C): 24.85
New Gain            : 0.995
New Offset          : 0.990
Calibration ready - remember SAVE command
>
```

9. As an exception you may receive an error message and no new values will be calculated:

```
Error: Calibration points too close - Not calibrated
```

10. Now type **SAVE**, press **Enter**. The new values are stored to EEPROM.

```
>save
EEPROM (basic) saved successfully
EEPROM (op) saved successfully
EEPROM (op_log1) saved successfully
EEPROM (op_log2) saved successfully
```

11. Type **ADJUST OFF**, press **Enter**. The adjustment is done and the outputs return to displaying the measurement results.

```
>adjust off
Outputs to normal state
```

## Two-Point Adjustment Using Local Interface

### Two-Point Adjustment Function (CAL2)

The procedure is the same as in one-point calibration but the adjustment continues automatically with the second reference point. Instructions for the two-point adjustment procedure using Local Interface are provided in the next section.

Adjustment can be interrupted at any time by pressing the **Back** key.



### Two-Point Adjustment Procedure Using Local Interface

As a result of this adjustment, new gain and offset parameter values are calculated and set. The two-point adjustment procedure is conducted by using one gas for adjusting the low end of the measurement range and then another gas for adjusting the high end of the measurement range. These can be, for example pure nitrogen (0.0 % O<sub>2</sub>) and an N<sub>2</sub>/O<sub>2</sub> mixture (for example, 21 % O<sub>2</sub>). The minimum difference between the two reference gas concentrations in two-point adjustment should be at least 4 % O<sub>2</sub>.

1. Select **Pass** from the menu and give the password.  
After the password is given, more options appear in the menu.
2. If the adjustment conditions (gas pressure, humidity, and CO<sub>2</sub> concentration) are different from the operating conditions of the transmitter, you have to set the environmental parameters of the adjustment environment to the transmitter for the duration of the adjustment. These settings must then be changed back to represent the process conditions when the transmitter is reinstalled in its operating environment. For more information on setting environmental parameters to OMT364, see [Chapter 6, Setting Environmental Parameters, on page 89](#).
3. Select **Cal2** from the menu. This starts the adjustment mode, provided there are no fatal errors active in the device. The adjustment mode freezes the analog output and the RUN/POLL modes to their current states.
4. Connect the first (low-end) reference point gas.
5. The display shows "Set Lo 0.0 %". Use the **Up/Dn** keys to set the correct concentration of the low-end reference gas (in 0.1 % steps). Accept the reading by pressing **Ent**. Please note that it is enough that the measured value is constant. The value itself is incorrect, because the adjustment is in progress.
6. The device switches to displaying the settling concentration reading. When the reading has stabilized, press **Ent** again.
7. The device asks for the second (high) reference point gas and the display shows "Set Hi 10.0 %". At this point, connect the high-end reference gas.  
  
The device again switches to displaying the settling concentration reading. When the reading has stabilized, press **Ent** again. If the adjustment has been successful, the text "PASS" is displayed.
8. The device now calculates the new gain and offset settings and starts displaying the normal measurement result. At this point either accept the adjustment by pressing **Ent** or cancel everything by pressing **Back**.

The displays return to displaying the measurement results.

## Restoring Factory Calibration

### Restore Factory Calibration Command (FCRESTORE)

To remove the customer calibration and restore the factory calibration, open the terminal program with valid serial communication settings and issue the command (password required):

Syntax: **FCRESTORE**<cr>

#### Example:

```
>fcrestore  
Customer calibration removed - remember SAVE command
```

Save the changes by issuing the command:

```
>save
```

### Restore Factory Calibration Function (Fac)

To remove the customer calibration and restore the factory calibration parameters, select the restore factory calibration function **Fac** (password required) and press **Ent** twice. The text "PASS" is displayed when the operation is successful.



#### NOTE

Issuing command **FCRESTORE** or selecting **Fac** sets parameters gain = 1 and offset = 0.



## CHAPTER 8

# **CALIBRATION AND ADJUSTMENT (AMBIENT GAS MEASUREMENT VERSION OF OMT364)**

In this User's Guide the term calibration refers to comparing the device's reading against a reference concentration. Adjustment refers to changing the device's reading to correspond to the reference concentration.

Read the instructions through carefully before making any adjustments or parameter changes. Vaisala accepts no responsibility for parameter or settings changes nor adjustments made by the user. When you require technical support or assistance, please contact Vaisala Technical Support (see, [Technical Support, on page 149](#)).

**CAUTION**

Special care must be taken when calibrating or adjusting the ambient measurement version of OMT364. With the ambient environment configuration it is assumed that the entire transmitter (both probe and transmitter housing) is installed in an environment of changing O<sub>2</sub> concentration that is to be measured.

This sets special requirements for calibration and adjustment of the ambient measurement version of OMT364, because the calibration and adjustment gas should be present both in the probe and inside the transmitter housing. This arrangement is often impractical. Therefore Vaisala recommends the following procedures which provide a simpler approach:

- For calibration (checking of the device): use normal ambient air or 21.0 % O<sub>2</sub> calibration gas. Refer to [Calibration on page 124](#).
- For adjustment: use one-point adjustment with 21.0 % O<sub>2</sub> adjustment gas and sample cell. Refer to [Adjustment on page 128](#).

More information about the ambient measurement version of OMT364 and its differences compared to the in-line version of the product can be found from OMT364 User's Guide, in [Chapter 2, Product Overview, on page 17](#).

## Hardware Arrangements for Calibration and Adjustment

### Getting Started

Calibration can be done simply by observing the measurement reading of the transmitter. Before calibration or adjustment the transmitter should be on for at least 15 minutes. Adjustment requires user access to serial line or local keypad interface:

1. Open the back cover of the transmitter with a 4 mm hex socket (Allen) key.
2. If you wish to use serial communication, connect the serial line cable and open the terminal program with valid serial communication settings (default settings are 19200/8/N/1). After the self test is completed, if necessary, stop printing oxygen measurement results with command **S** (or by pressing **Esc**).

3. Connect the appropriate gas arrangements (see [Gas Feed Setup for Calibration and Adjustment on page 123](#)), and follow proper calibration or adjustment procedure (see [Calibration on page 124](#) and [Adjustment on page 128](#)).

## Gas Feed Setup for Calibration and Adjustment

The ambient measurement version of OMT364 requires the calibration and adjustment gas to be present both in the probe and inside the transmitter housing.

This requirement is most easily fulfilled by doing calibration and adjustment with gas that has O<sub>2</sub> concentration close to normal ambient air O<sub>2</sub> concentrations (20.95 %O<sub>2</sub>).

### Using Ambient Air

Ambient air may be used for calibration purposes. In this case, it is sufficient to expose the transmitter to ambient conditions. For calibration procedures, see [Using Ambient Air on page 124](#).

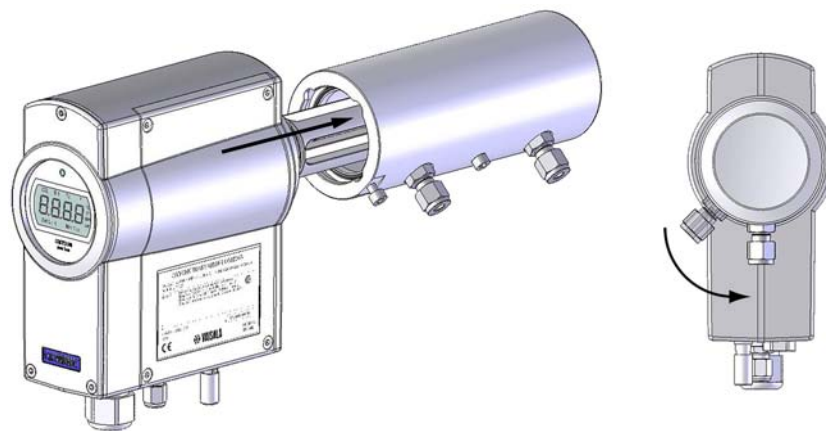
### Using Bottled Calibration Adjustment Gas

Insert probe into the sample cell. Push it slightly down and turn it clockwise 45°. If you have problems while inserting the probe, check that the O-ring is located properly in its groove. The calibration gas inlets are equipped with 1/8" NPT gas fittings for ø 6 mm tubing. Let the gas flow freely out, so that there is no overpressure in the chamber.

The ambient measurement version of OMT364 requires the calibration and adjustment gas to be present both in the probe and inside the transmitter housing. In the setup described above, gas inside the transmitter housing would be normal ambient air, so it is necessary that the calibration/adjustment gas O<sub>2</sub> concentration is at or close to ambient air (20.95 %O<sub>2</sub>).

If calibration or adjustment gas concentrations significantly different from ambient air are used, it should be noted that:

- For calibration (checking of the device), it is possible to correct the transmitter reading for the error that is caused by the calibration setup (calibration gas not fed into the transmitter housing), see chapter [Using Calibration Gas on page 125](#).
- For adjustment, needed arrangements should be carried out to have the adjustment gas concentration present in the transmitter housing, also.



**Figure 26** Attaching OMT364 Probe into Sample Cell

## Calibration

### Using Ambient Air

Normal ambient air provides a convenient way to calibrate the OMT364, because the oxygen concentration of dry ambient air is constant 20.95 %O<sub>2</sub>. Furthermore, exposing the transmitter to normal ambient air naturally fulfills the requirement for calibration gas arrangements (the calibration gas, that is ambient air, is present both in the probe and in the transmitter housing).

Calibration with ambient air is done simply by exposing the transmitter to ambient conditions and observing the O<sub>2</sub> reading. When calibrating with dry ambient air, the oxygen reading should be 21.0 %O<sub>2</sub> ±0.2 %O<sub>2</sub>. In practice, ambient air is seldom dry and

humidity correction is needed. The chart in [Figure 27 on page 125](#) below shows the expected calibration reading with ambient air as function of temperature (T) and relative humidity (%RH).

The oxygen readings (in units of %O<sub>2</sub>) when measuring gas concentration of 20.95%O<sub>2</sub> with alternating humidity, are given in the chart below. It gives an example of readings when measuring humid gases with no RH corrections given to the OMT364 transmitter (that is, RH is set as 0%RH). Both gas dilution effect and RH dependency effect are included in the chart.

T [C]	Relative Humidity [%RH]										
	0	10	20	30	40	50	60	70	80	90	100
0	21.0	21.0	21.0	21.0	20.9	20.9	20.9	20.9	20.9	20.9	20.8
5	21.0	21.0	21.0	20.9	20.9	20.9	20.9	20.8	20.8	20.8	20.8
10	21.0	21.0	20.9	20.9	20.9	20.8	20.8	20.8	20.7	20.7	20.7
15	21.0	21.0	20.9	20.9	20.8	20.8	20.7	20.7	20.6	20.6	20.6
20	21.0	20.9	20.9	20.8	20.8	20.7	20.6	20.6	20.5	20.4	20.4
25	21.0	20.9	20.8	20.8	20.7	20.6	20.5	20.4	20.3	20.3	20.2
30	21.0	20.9	20.8	20.7	20.6	20.4	20.3	20.2	20.1	20.0	19.9
35	21.0	20.9	20.7	20.6	20.4	20.3	20.1	20.0	19.8	19.7	19.6
40	21.0	20.8	20.6	20.4	20.2	20.1	19.9	19.7	19.5	19.3	19.1
45	21.0	20.8	20.5	20.3	20.0	19.8	19.5	19.3	19.1	18.8	18.6
50	21.0	20.7	20.4	20.1	19.7	19.4	19.1	18.8	18.5	18.2	17.9
55	21.0	20.6	20.2	19.8	19.4	19.0	18.6	18.3	17.9	17.5	17.2
60	21.0	20.5	20.0	19.5	19.0	18.5	18.1	17.6	17.1	16.7	16.2
65	21.0	20.4	19.7	19.1	18.5	17.9	17.3	16.8	16.2	15.6	15.1
70	21.0	20.2	19.4	18.7	17.9	17.2	16.5	15.8	15.1	14.4	13.8
75	21.0	20.0	19.1	18.2	17.3	16.4	15.5	14.7	13.8	13.0	12.2
80	21.0	19.8	18.7	17.5	16.5	15.4	14.4	13.4	12.4	11.4	10.4

**Figure 27** Oxygen Readings in Alternating Humidity

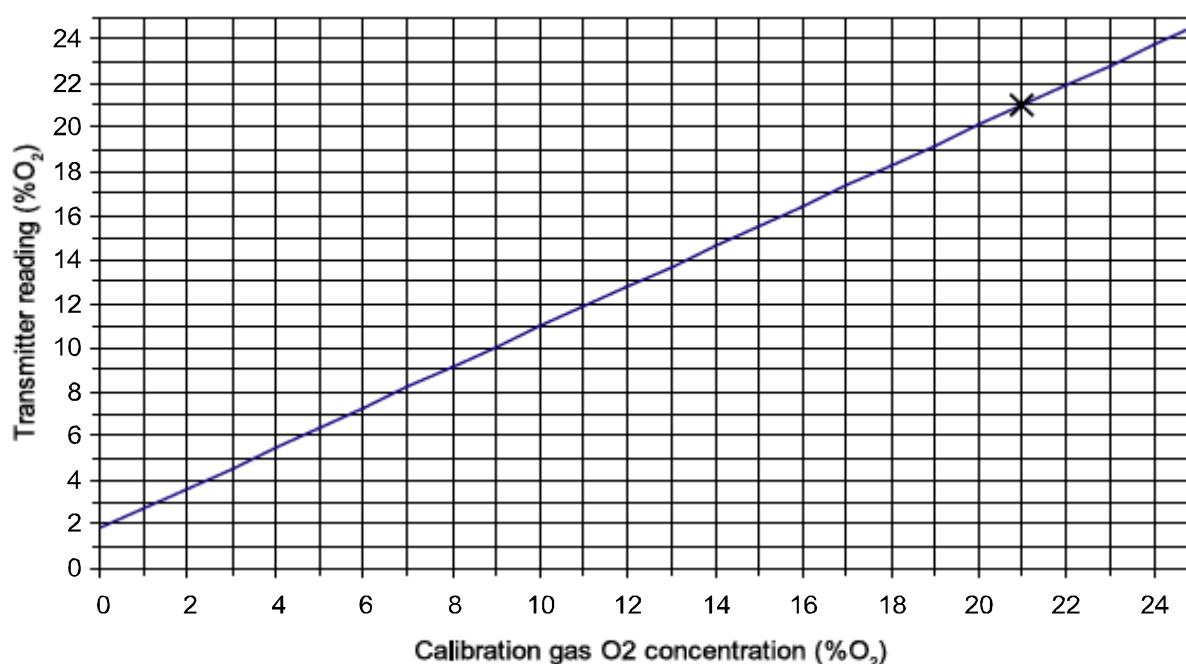
## Using Calibration Gas

For simple calibration of the ambient measurement version of OMT364, Vaisala recommends using normal ambient air, see [Using Ambient Air on page 124](#).

If a calibration gas (like synthetic air or precision O<sub>2</sub> concentration gas) is used, refer to [Hardware Arrangements for Calibration and Adjustment on page 122](#) and [Using Bottled Calibration Adjustment Gas on page 123](#) for arranging the setup.

Since only the probe part of the transmitter is in the known O<sub>2</sub> concentration (that is, the O<sub>2</sub> concentration of the calibration gas), the ambient gas measurement version of the OMT364 transmitter will not display the calibration gas concentration. In this kind of a calibration gas arrangement, the correct reading for the ambient measurement version of OMT364 can be seen from the chart in [Figure 28 on page 126](#).

The figure shows the readings of the ambient gas measurement version of OMT364 when calibration gas is fed only to the sample cell (that is, transmitter housing is not in the calibration gas environment).



**Figure 28** Calibration Gas O<sub>2</sub> Concentration Readings for Ambient Gas Measurement Version of OMT364

## Information on Calibration Gases

The factory calibration of OMT364 is carried out using dry N<sub>2</sub> and O<sub>2</sub> mixtures. Humidity and CO<sub>2</sub> concentration of the calibration gases are 0 %. Nitrogen mixture gases are recommended for adjustment of OMT364. For calibration and adjustment of OMT364, gas flow rate of about 0.5 l/min is adequate, but for a faster response during calibration and adjustment, use higher flow rates. Note however, that with high

flow rates, the gas pressure is higher, and you need to use large enough tubing for the outgoing gas.

**NOTE**

Allow enough time for the gas concentration to stabilize when doing calibrations/adjustments.

## Calibration Procedures

### Lock Outputs for Calibration Command (ADJUST)

This command locks all the outputs to their current values or frees them from the lock. This command can be used for checking the calibration against a known reference gas, or during on-line adjustment, so process control is not disturbed by the changing readings.

Syntax: **ADJUST** [on/off]<cr>

**Example:** >adjust on Outputs (analog, relay, POLL/Run and MT300) frozen

### Calibration Check Function (Cal.C)

When the calibration check function **Cal.C** has been selected, you can check the calibration using a reference gas. At the same time the analog output is frozen to the state preceding the time the calibration check operation was activated. The calibration check mode is stopped by pressing **Ent**.



## Adjustment

For ambient measurement version of OMT364 Vaisala recommends a one point adjustment with a dry O<sub>2</sub>/N<sub>2</sub> gas mixture with an O<sub>2</sub> concentration of about 21 %O<sub>2</sub>.

The ambient measurement version of OMT364 requires the adjustment gas concentration to be present in the probe and inside the transmitter housing.

To simplify adjustment arrangements, the adjustment gas concentration should be at or near the oxygen concentration of normal ambient air (20.95 %O<sub>2</sub>). This way, the adjustment gas may be fed only into the sample cell, and the gas concentration inside the transmitter housing would be ambient air. Refer to [Hardware Arrangements for Calibration and Adjustment on page 122](#) and [Gas Feed Setup for Calibration and Adjustment on page 123](#).

**NOTE**

Adjustment features are password protected. After entering the password, it expires in 30 minutes. If the password expires while a password protected function is running, the function will still be completed. To access password protected features after the password has expired, re-enter the password.

**NOTE**

If there are any errors active in the device, adjustment might fail at any point during the procedure. Therefore it is recommended that you clear all errors before attempting any adjustments. For instructions on clearing nonfatal errors and warnings, see [Error Display on page 147](#).

**NOTE**

Make sure that environmental parameters are set according to the adjustment environment before attempting any adjustments. Set the pressure, humidity, and CO<sub>2</sub> concentration values of the adjustment gas. Typically the humidity of the calibration gases is 0 g/m<sup>3</sup>H<sub>2</sub>O. CO<sub>2</sub> concentration of nitrogen mixture gases is usually 0 vol-% CO<sub>2</sub>. After making the adjustment, set the environmental parameters back to represent the values of the process gas. For more information about environmental parameter compensations, see [Environmental Parameter Compensations on page 89](#).

## Possible Adjustments for Ambient Measurement Version

The following adjustments are available to the customer:

- One-point adjustment (at or near 21.0 %O<sub>2</sub>) using the serial line
- One-point adjustment (at or near 21.0 %O<sub>2</sub>) using the Local Interface
- Restoring the factory calibration

One-point adjustment changes either the measurement gain or offset value. If the given reference gas O<sub>2</sub> concentration is >10.5 %O<sub>2</sub>, the result of one-point adjustment is a new gain value, otherwise the result is a new offset value. The result of two-point adjustment would be both new gain and offset values.

## One-Point Adjustment Using Serial Line

This command is used to make a one-point adjustment.

### One-Point Adjustment Command (COXY1) and Procedure Using Serial Line

As a result of this adjustment, new gain or offset parameter value (depending on the reference concentration used) is calculated and set.

1. Type **PASS "XXXX"** (the password) and press **Enter** (on your computer keyboard).
2. Type **ADJUST ON**, press **Ent**.

```
>adjust on
```

```
Outputs (analog, relay, POLL/Run and MT300) frozen
```

This command locks all the outputs to their current values. This command should be used during on-line adjustment, so process control is not disturbed by the changing readings. If the device is removed from the process or disconnected from process controls during adjustment, this step can be omitted.

If the adjustment conditions (gas pressure, humidity, and CO<sub>2</sub> concentration) are different from the normal operating conditions of the transmitter, you have to set the environmental parameters of the adjustment environment to the transmitter for the duration of the adjustment. These settings must then be changed back to represent the process conditions when the transmitter is reinstalled in its operating environment. For more information on setting environmental parameters to OMT364, see [Chapter 6, Setting Environmental Parameters, on page 89](#).

3. Type the one-point adjustment command **COXY1** and press **Enter**.

4. Connect the gas inflow in place and start the gas flow.

The calibration starts. At this stage, you may opt to use the following commands:

- **Enter** - The most recent measurement result is printed or continuous printing is stopped.
- **R + Enter** - Measurement results are printed continuously at approximately one second intervals. Press **Enter** again to stop printing results.
- **Esc** - Abort the calibration.

5. Observe when the reading has stabilized. Type the reference gas concentration and press **Enter**.

A new gain or offset parameter value is now calculated and displayed.

The output after giving the **COXY1** command:

```
>coxy1
Customer calibration
Current condition/settings:
Pressure (bar)           : 1.013
H2O (g/m3)              : 0
CO2 (vol-%)             : 0
Gas temperature (C)     : 23.64
Internal temperature (C): 24.84
If parameters are not correct, cancel calibration by
ESC and change parameters.
Connect ref gas to cuvette.
O2 (%): 20.52 Ref ?
O2 (%): 20.51 Ref ?
O2 (%): 20.51 Ref ? 20.50
Calibration data:
```

```
Pressure setting (bar) : 1.013
Measured oxygen       : 20.51
Given oxygen          : 20.50
Gas temperature (C)   : 23.65
Ref path temperature (C): 24.85
New Gain              : 1.000
Calibration ready - remember SAVE command
```

6. Now type **SAVE**, press **Enter**. The new values are stored to EEPROM.

```
>save
EEPROM (op) saved successfully
EEPROM (op_log1) saved successfully
EEPROM (op_log2) saved successfully
```

7. Type **ADJUST OFF**, press **Enter**.

```
>adjust off
Outputs to normal state
```

The adjustment is done and the outputs return to displaying the measurement results.

## One-Point Adjustment Using Local Interface

### One-Point Adjustment Function (CAL1)

When the one-point calibration function **Cal1** has been selected, the analog output is frozen.

Attach the reference gas and perform the adjustment according to instructions in [Calibration and Adjustment \(Ambient Gas Measurement Version of OMT364\) on page 121](#), mainly in sections [Gas Feed Setup for Calibration and Adjustment on page 123](#) and [One-Point Adjustment Using Local Interface on page 131](#).

Adjustment can be interrupted at any time by pressing the **Back** key.



## One-Point Adjustment Procedure Using Local Interface

Depending on the reference concentration used, this adjustment changes the gain or offset parameter value. At oxygen concentrations below 10.5 %O<sub>2</sub>, the offset value is changed, and above 10.5 %O<sub>2</sub> the gain value is changed.

1. Select **Pass** from the menu and give the password.

After the password is given, more options appear in the menu.

If the adjustment conditions (gas pressure, humidity, and CO<sub>2</sub> concentration) are different from the operating conditions of the transmitter, you have to set the environmental parameters of the adjustment environment to the transmitter for the duration of the adjustment. These settings must then be changed back to represent the process conditions when the transmitter is reinstalled in its operating environment. For more information on setting environmental parameters to OMT364, see [Chapter 6, Setting Environmental Parameters, on page 89](#).

2. Select **Cal1** from the menu.

This starts the adjustment mode, provided there are no fatal errors active in the device. The adjustment mode freezes the analog output and the RUN/POLL modes to their current states.

3. Connect the reference gas.

The display shows "Set 20.0 %".

4. Use the **Up** and **Dn** keys to set the correct concentration of the reference gas (in 0.1 % steps). Accept the reading by pressing **Ent**. The device switches to displaying the settling concentration reading.

Please note that it is enough that the measured value is constant. The value itself is incorrect, because the adjustment is in progress.

5. When the reading has stabilized, press **Ent** again.

If the adjustment has been successful, the text **PASS** is displayed. The device now calculates the new gain or offset settings and starts displaying the normal measurement result.

6. At this point either accept the adjustment by pressing **Ent** or cancel everything by pressing **Back**.

The displays return to displaying the measurement results.

## Restoring Factory Calibration

### Restore Factory Calibration Command (FCRESTORE)

To remove the customer calibration and restore the factory calibration, open the terminal program with valid serial communication settings and issue the command (password required):

Syntax: **FCRESTORE**<cr>

#### Example:

```
>fcrestore  
Customer calibration removed - remember SAVE command
```

Save the changes by issuing the SAVE command:

```
>save
```

## Restore Factory Calibration Function (Fac)

To remove the customer calibration and restore the factory calibration parameters, select the restore factory calibration function **Fac** (password required) and press **Ent** twice. The text "PASS" is displayed when the operation is successful.

**NOTE**

Issuing command **FCRESTORE** or selecting **Fac** sets parameters gain = 1 and offset = 0.

## CHAPTER 9

# MAINTENANCE

## Field Maintenance

### Cleaning the Optics

**CAUTION**

OMT364 is a Class 1 laser product.

Normal handling and operation of the device is eye-safe, because laser radiation is collimated and maintained inside the probe, as is schematically shown in [Figure 7 on page 24](#). No laser radiation is emitted outside the probe.

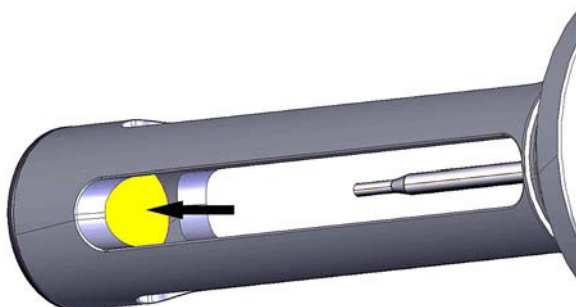
However, cleaning the optics requires user access to the optical surfaces inside the probe. The transmitter should be switched off during any cleaning procedures, so that cleaning tools etc. placed into the probe cannot cause a reflection of laser radiation outside the probe.

OMT364 is designed for industrial processes and can tolerate some dirt on the optics as the measurement is compensated for reduction of signal. Still, it is important to keep the optics as clean as possible and it is recommended that the optics be cleaned whenever any maintenance procedures are performed, or whenever the transmitter issues a maintenance warning or error signal informing of excessive light loss in the sensor. You can check the signal level through the serial or local interface, see [Measure Signal Level Command \(SIL\) on page 84](#) and [Signal Level Display Function \(Sil\) on page 85](#).

## Using Solvents to Clean the Optics

When using solvents to clean the optics, make sure the solvent used is compatible with the sealing material used in the transmitter. Refer to section [Chemical Tolerance on page 28](#) for chemical tolerance of sealing materials used in OMT364.

## Cleaning the Mirror

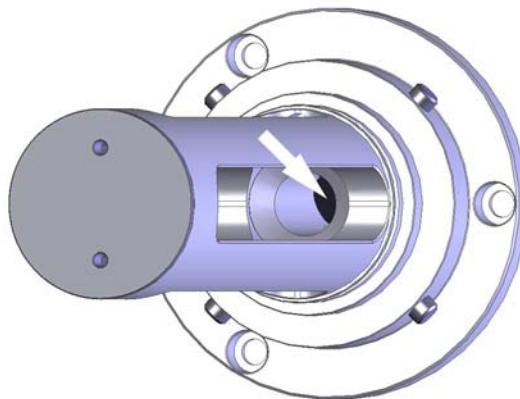


**Figure 29** Location of Mirror in Oxygen Measurement Probe

1. Remove the filter. For instructions, see [Filter Change on page 138](#).
2. Blow clean, instrument-grade or cleaner air on the mirror to remove loose particles. In case there is still some dirt on the optics, proceed to step 3.
3. Pour some distilled water on the mirror so that the entire mirror surface is covered with water. Pour out excess water.
4. Take a piece of soft, clean paper tissue (optical or clean room grade tissue) and gently dry the surface with rotating movements.
5. If the surface still seems dirty after water cleaning, redo the cleaning with, for example, pure ethanol or isopropanol (or some other suitable solvent, see [Using Solvents to Clean the Optics on page 136](#)). Be careful while pouring out the excess liquid so that the optical surface at the opposite end of the probe does not get wet.

After the cleaning, the surfaces should look like a clean mirror surface. There should not be any oily stains, spots or dust. Replace the filters after cleaning.

## Cleaning the Lens



**Figure 30** Location of Lens in Oxygen Measurement Probe

**NOTE**

The lens is located in the bottom of a  $\varnothing$  11,5 mm cavity and can be hard to reach. Take care not to damage the lens under any circumstances.

1. Remove the filters. For instructions, see [Filter Change on page 138](#).
2. Use clean, instrument-grade or cleaner air to remove dust, loose particles and other such dirt.
3. Then, if necessary, use distilled water to remove water-soluble dirt.
4. If the surface still seems dirty after water cleaning, redo the cleaning with, for example, pure ethanol or isopropanol (or some other suitable solvent, see [Using Solvents to Clean the Optics on page 136](#)). Be careful while pouring out the excess liquid so that the optical surface not being cleaned does not get wet.

Replace the filters after cleaning.

**CAUTION**

Physical cleaning (rubbing) of the lens with, for example, a cotton stick is not permitted.

## Replacing Consumables

### OMT364 Filters



**Figure 31**     **Stainless Steel Mesh and PTFE Filters**

To avoid contamination, handle the PTFE filter only by the solid part at the open end of the filter or by the closed tip and the very edges of the closed end of the filter (these areas are inactive once the filter is installed on the probe). The arrows in [Figure 31 on page 138](#) indicate the safe spots to handle the PTFE filter.

## Filter Change

### Cleaning and Changing the Stainless Steel Mesh Filter

The mesh filter is made of acid-proof stainless steel and it can be cleaned with most common cleaning agents. To clean the filter, first remove it from the transmitter. After cleaning, thoroughly dry the filter and make sure that air can pass through the filter mesh before reinserting it to the transmitter.

The stainless steel filter needs to be replaced when it remains dirty or clogged despite thorough cleaning. The filter is changed as follows:

1. Unscrew and remove the stainless steel mesh filter.
2. Replace the filter with a new one and tighten it in its place.

## Changing the PTFE Filter

### CAUTION

To avoid contamination, handle the PTFE filter only by the parts indicated in [Figure 31 on page 138](#).

Avoid touching, rubbing, or scraping the active surfaces of the PTFE filter as this can clog the filter.

The PTFE filter is highly effective at preventing liquid water from entering the measurement optics. It also provides good protection against dust and other dirt and contaminants with small particle size, but it is still permeable to solvents and water vapor. The PTFE filter needs to be checked and changed often enough to provide adequate gas flow to the sensor volume. The filter is changed as follows:

1. The PTFE filter is locked in place by the ridge at the base of the oxygen measurement probe. Grasp the filter firmly, slide it over the ridge and pull the filter loose. Adhere to the instructions above when handling the filter.
2. Slide and lock the filter into its place by holding the filter only by the solid part at the open end of the filter or (if necessary) by pressing with your fingers at the closed tip of the filter.

### NOTE

It can be awkward to remove the PTFE filter from the mesh filter. They tend to come off the transmitter together.



# CHAPTER 10

## TROUBLESHOOTING

### Operation Errors

OMT364 monitors its operation and the condition of many hardware components. Errors can be detected during the self-test and normal operation. If error occurs, the transmitter sets itself to a special state depending on the severity of the error.

### Self-Test

During start-up, the transmitter runs a self-test, which is used to check several things concerning functions of the transmitter electronics and measurement signals.

#### Example of the transmitter self-test output:

```
OMT300 - Version STD 1.08
Vaisala Oyj, 2004-2006

>
-----
SELF TEST STARTS

Voltages:                               OK
TEC current sense zero:                 OK
I/O Expander:                           OK
LCD Drivers:                             OK
ADC2 communication:                     OK
Digipots communication:                 OK
Temperature measurements:                 OK
```

```
Peltier Driver:          OK
Laser current:          OK
Signal from sensor:     OK
Gain and offset controls: OK
```

```
SELF TEST ENDS
-----
```

```
ERR EVENT:ACT 37:NO MEASUREMENT RESULTS
>
ERR EVENT:ACT 33:LASER TEMPERATURE NOT REACHED
>
ERR EVENT:DEACT33:LASER TEMPERATURE NOT REACHED
>
ERR EVENT:DEACT37:NO MEASUREMENT RESULTS
>
```

As the above example of the transmitter self-test output shows, immediately after the test, two errors are active (#33: LASER TEMPERATURE NOT REACHED and #37: NO MEASUREMENT RESULTS). This is normal, and after a few moments the laser temperature will be reached and the transmitter starts outputting readings.

Some external conditions may also result in the transmitter failing the self-test, for example a fully condensed probe with a misty lens and mirror. In such a situation, the signal level is not sufficient, but the external conditions may improve after some time. The transmitter resets after 10 minutes, if the self-test has failed due to factors that may have been caused by external conditions.

## Error Detection During Operation

During the operation, the transmitter monitors several signal levels, for example the state of the laser. Possible errors during operation include, for example, low signal level (#31: SIGNAL LEVEL LOW), analog output range (#38: ANALOG OUTPUT RANGE), or unstable laser temperature (#33: LASER TEMPERATURE NOT REACHED).

A likely cause for low signal level is condensation or dirt in the lens and/or mirror. Analog output range error is reported when the oxygen measurement and reading are ok, but cannot be sent through the analog output, because the scaling is such that the signal goes out of range. In case of this error, rescale the analog output to the proper range.

The laser temperature may typically become unstable in two different types of situation. The diode laser semiconductor chip needs to be kept in constant temperature for its operation. So if there is a rapid temperature change, the laser temperature might temporarily go out of range, but the laser temperature controller will usually correct this in a matter of seconds.

However, the transmitter hardware is limited in its capacity to maintain a temperature difference between the chip and its surroundings. For example, the cooling capacity of the hardware is at its maximum at 80 °C, so if this temperature is exceeded, the transmitter displays the error message and sets the non-fatal error state which will not clear until the process conditions improve.

## Error Control and Error Categories

Errors are divided into three categories:

- Fatal errors, which lead to the permanent error state. The device almost certainly requires service.
- Nonfatal errors are deactivated automatically if certain conditions are met. These errors can also be deactivated manually.
- Warnings. With warnings, measurement continues but a service request is given. Warnings can be deactivated manually.

All errors are always cleared at start. Error events are stored in EEPROM.

## Fatal Errors

The table below lists the different transmitter outputs when fatal error has been detected.

**Table 9 Actions When Fatal Error Has Been Detected**

Analog output	Programmable, default = 3 mA
LED	Red LED is blinking fast
Relay	Open
Display	Error codes are displayed
Service Interface	STOP-MODE: Send error message RUN-MODE: O2 value = ***. ** POLL-MODE: O2 value = ***. **
Customer Interface	STOP-MODE: Send error message RUN-MODE: O2 value = ***. ** POLL-MODE: O2 value = ***. **
Error counter	Error counter(s) increased
Error log	Error is written to log

## Nonfatal Errors

The table below lists the different transmitter outputs when nonfatal error has been detected.

**Table 10 Actions When Nonfatal Error Has Been Detected**

Analog output	Programmable, default = 3 mA
LED	Red LED is blinking slowly
Relay	Open
Display	Error codes are displayed <sup>1</sup>
Service Interface	STOP-MODE: Send error message RUN-MODE: O2 value = ***. ** POLL-MODE: O2 value = ***. **
Customer Interface	STOP-MODE: Send error message RUN-MODE: O2 value = ***. ** POLL-MODE: O2 value = ***. **
Error counter	Error counter(s) increased
Error log	Error is written to log

1. In case of error #38: ANALOG OUTPUT RANGE, the display switches between the error message and oxygen reading. This is because the oxygen measurement and reading are ok, but they can not be sent through the analog output because the scaling is such that the analog signal goes out of range.

## Warnings

The table below lists the different transmitter outputs when warning has been detected.

**Table 11**      **Actions When Warning Has Been Detected**

Analog output	Normal operation
LED	Green LED is blinking
Relay	Normal operation
Display	Normal operation
Service Interface	STOP-MODE: Send error message RUN-MODE: Normal operation POLL-MODE: Normal operation
Customer Interface	STOP-MODE: Send error message RUN-MODE: Normal operation POLL-MODE: Normal operation
Error counter	Error counter(s) increased
Error log	Error is written to log

## Emergency Shutdown State

In addition to the above error categories, there are certain faults such as processor failure and memory error that set the transmitter into the emergency shutdown state and the device will not start. The states of the different transmitter outputs in the emergency shutdown state are listed in the table below:

**Table 12**      **Emergency Shutdown Actions**

Analog output	0.0 mA
LED	Red LED on
Relay	Open

## Show Error Control Status (ERR)

This command displays the status of the error control object and active errors.

Syntax: **ERR**<cr>

**Example:**

```
>err
*** ERROR CONTROL (ERR) ***
Mode           : ON
State          : WARNING
ERRORS:
WARNING        : WATCHDOG RESET OCCURRED
>
```

## Show Error Log (ERRL)

This command displays the events in the error log.

Syntax: **ERRL**<cr>

**Example:**

```
>errl
T(h)T(ms)EventError
3043991ACT NO MEASUREMENT RESULTS
30461191ACT LASER TEMPERATURE NOT REACHED
30478691DEACTLASER TEMPERATURE NOT REACHED
30499091DEACTDEACTNO MEASUREMENT RESULTS
>
```

## Show Detected Errors (ERRS)

This command displays all errors currently active in the device.

Syntax: **ERRS**<cr>

**Example:**

```
>errs
ERROR: LOW SIGNAL
ERROR: FP SLOPE FAILURE
>
```

## Show Error Table (ERRT)

This command displays the error table.

Syntax: **ERRT**<cr>

**Example:**

```
>errt
# :St :Cnt :CategoryError text
 1:OFF: 0:FATALEEPROM BASIC PARAMS NOT AVAILABLE
 2:OFF: 0:FATALEEPROM OPERATION PARAMS NOT AVAILABLE
...
31:OFF: 0:NON FATALSIGNAL LEVEL LOW
32:OFF: 0:NON FATALSIGNAL CUT
...
52:OFF: 0:WARNINGEEPROM LOG&STATS CORRUPTED
53:OFF: 0:WARNINGWATCHDOG RESET OCCURRED
```

## Error Display

If there are no errors the text "E 00" is displayed.

Whenever there are errors the most severe error is shown first. The other errors can be seen by scrolling up and down the error list by pressing the **Up/Dn** keys. Nonfatal errors and warnings can be reset by pressing **Ent** twice.

A rectangular LCD display showing the text "Err" in a monospaced font.

A rectangular LCD display showing the text "E 00" in a monospaced font.

A rectangular LCD display showing the text "E 20" in a monospaced font.

## Error Table

The table below lists the errors detected by the OMT364 software. The most severe errors are listed first. The error text associated with each error gives a description of the cause of the error.

**Table 13 Error Table**

Error Number #	Error Category	Error Text
1	FATAL	EEPROM BASIC PARAMS NOT AVAILABLE
2	FATAL	EEPROM OPERATION PARAMS NOT AVAILABLE
3	FATAL	LASER CURRENT OUT OF RANGE
4	FATAL	SIGNAL LEVEL HIGH
5	FATAL	LASER TEMPERATURE SENSOR FAILURE
6	FATAL	GAS 1 TEMPERATURE SENSOR FAILURE
7	FATAL	GAS 2 TEMPERATURE SENSOR FAILURE
8	FATAL	IO-EXPANDER CONNECTION
9	FATAL	LCD-DRIVER CONNECTION
10	FATAL	ADC2
11	FATAL	DIGIPOT CONNECTION
12	FATAL	PELTIER
13	FATAL	LASER CURRENT MEASUREMENT
14	FATAL	FRONT END CONTROLS
15	FATAL	PELTIER CURRENT SENSE
16	FATAL	VAC LIMIT REACHED
17	FATAL	SUPPLY VOLTAGES
31	NONFATAL	SIGNAL LEVEL LOW
32	NONFATAL	SIGNAL CUT
33	NONFATAL	LASER TEMPERATURE NOT REACHED
34	NONFATAL	PEAK LOST
35	NONFATAL	TOO LOW SUPPLY VOLTAGE
36	NONFATAL	ANALOG OUTPUT LOAD TOO HIGH
37	NONFATAL	NO MEASUREMENT RESULTS
38	NONFATAL	ANALOG OUTPUT RANGE
51	WARNING	SIGNAL QUITE LOW
52	WARNING	EEPROM LOG&STATS CORRUPTED
53	WARNING	WATCHDOG RESET OCCURRED

## Technical Support

For technical questions, contact the Vaisala technical support:

E-mail [helpdesk@vaisala.com](mailto:helpdesk@vaisala.com)

Fax +358 9 8949 2790

## Return Instructions

If the product needs repair, please follow the instructions below to speed up the process and to avoid extra costs.

1. Read the warranty information.
2. Contact a Vaisala Service Center, preferably by e-mail or fax and request for instructions. Please include a problem report describing the problem.
3. Proceed as instructed by Vaisala service personnel.

## Vaisala Service Centers

Vaisala Service Centers perform calibrations and adjustments as well as repair and spare part services. Vaisala SPECTRACAP<sup>®</sup> Oxygen Transmitter OMT364 maintenance is performed by the European Service Center:

### European Service Center

Controlled Environments and Instruments  
Vanha Nurmijärventie 21, FI-01670 Vantaa, FINLAND

Phone +358 9 8949 2658

Fax +358 9 8949 2295

E-mail [helpdesk@vaisala.com](mailto:helpdesk@vaisala.com)

Website [www.vaisala.com](http://www.vaisala.com)



## CHAPTER 11

# TECHNICAL DATA

## Specifications

**Table 14 Performance**

Property	Description / Value
Typical measurement ranges (scalable) for process measurement for ambient air measurement	0 ... 25 %O <sub>2</sub> 2 ... 25 %O <sub>2</sub>
Accuracy, including noise, linearity and repeatability	±0.2 %O <sub>2</sub>
Temperature dependence over T-range	±2 % of reading, max. dT/dt 1 °C/min
Stability	zero drift ±0.1 %O <sub>2</sub> / year span drift ±0.8 % of reading / year
Response time of measurement (T <sub>63</sub> /T <sub>90</sub> ) in still air without filter with Stainless Steel Net with Stainless Steel Net and PTFE	10 s / 20 s 10 s / 25 s 30 s / 70 s
Pressure dependence when compensation is enabled	± 0.25 ... 0 % of reading (0.8 ... 1.4 bar <sub>a</sub> )
Pressure dependence when compensation is disabled	- 2 ... 0 % of reading (0.8 ... 1.2 bar <sub>a</sub> ) - 5 ... 0 % of reading (0.8 ... 1.4 bar <sub>a</sub> )
Operating pressure range	0.8 ... 1.4 bar <sub>a</sub>
Power up time	2.5 min
Warm-up time (to full specification)	3 min

**Table 15 Background Gas Effect**

Property	Description / Value
The effect of CO <sub>2</sub> (0 ... 50 vol-%CO <sub>2</sub> ) on the O <sub>2</sub> reading if compensation is disabled if compensation is enabled	- 0.15 % of reading / vol-% CO <sub>2</sub> ± 0.5 % of reading
The effect of humidity (g/m <sup>3</sup> H <sub>2</sub> O) the O <sub>2</sub> reading if compensation is disabled  if compensation is enabled	- 0.03 % of reading / g/m <sup>3</sup> H <sub>2</sub> O  ± 0.5 % of reading (0 ... 100 g/m <sup>3</sup> H <sub>2</sub> O) ± 1 % of reading (0 ... 300 g/m <sup>3</sup> H <sub>2</sub> O) NOTE: 300 g/m <sup>3</sup> H <sub>2</sub> O equals to 100 %RH @ 80 °C

**Table 16 Operating Environment**

Property	Description / Value
Operating temperature range for probe (in-line installation) for electronics (housing) for transmitter (ambient air measurement)	-20 ... +80 °C/ -4 ... 176°F -20 ... +60 °C/ -4 ... 140°F -20 ... +60 °C/ -4 ... 140°F
Storage temperature range	-55 ... +80 °C/ -67 ... 176°F
Operating pressure range	0.8 ... 1.4 bar <sub>a</sub>
CE compliant	IEC(EN)-61326
Safety	Class 1 laser product, see <a href="#">Eye Safety on page 24</a> and <a href="#">Cleaning the Optics on page 135</a> for instructions on eye-safe handling of the device.

**Table 17 Inputs and Outputs**

Property	Description / Value
Power supply input range	11 ... 36 VDC
Power consumption maximum typical	6 W @ 80 °C 3 W @ 25 °C
Maximum current consumption U <sub>in</sub> = 11 VDC U <sub>in</sub> = 24 VDC	550 mA 250 mA

**Table 17 Inputs and Outputs**

Property	Description / Value
Analog output	0/4 ... 20 mA, sourcing
Maximum load	500 $\Omega$
Accuracy	$\pm 0.05$ % of FS
Temperature dependency	$\pm 0.005$ % / $^{\circ}\text{C}$
Serial output (2-wire, nonisolated)	RS-485
Alarm/control relay	30 VAC / 60 VDC
Serial output (NOTE: for service use only in safe area)	RS232C
Connections	screw terminals, 0.5 ... 1.5 mm <sup>2</sup> RJ45 connector for RS232C
Display	7-segment LCD
LED	Two-colors; red/green
Resistance between signal ground and earth	10 M $\Omega$

**Table 18 Approvals and Fulfilled Standards**

Property	Description / Value
Factory Mutual (FM):	OMT364 Oxygen Transmitter is approved for Class I, Division 2, Groups A, B, C and D. Sensor for Class I, Division 1 and 2, Groups A, B, C and D hazardous indoor and outdoor locations with an enclosure rating IP66. Temperature class T4.
	Classified as Class 1 laser device in accordance with IEC 60825-1. CDRH accession number: 07R0485-000.

**Table 19 Dimensions and Mechanics**

Property	Description / Value
Dimensions (h x w x d)	306 x 184 x 74 mm
Weight	2.2 kg
Housing material	G-AISI10Mg (DIN 1725)
Housing classification	IP66

**Table 19 Dimensions and Mechanics**

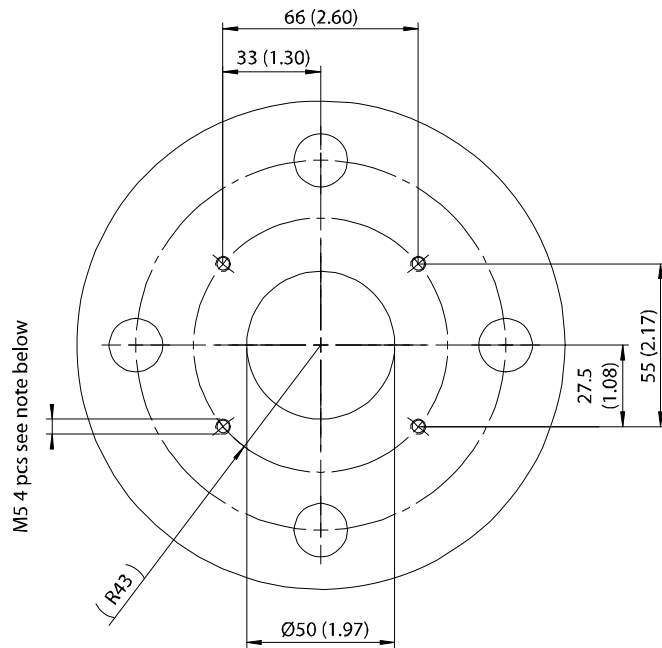
Property	Description / Value
Flange diameter	96 mm <i>Can be attached to DIN/ANSI standard flanges. Minimum flange sizes: DIN (2527B) DN50 mounted with M16 DIN933 or similar ANSI (150) 2.5" mounted with UNC 3/4"-10 or similar</i>
Cable bushing	cable gland, M20x1.5 for cable diameter 8 ... 11 mm conduit fitting ½" NPT
Filter	stainless steel mesh, holes 0.31 mm, wire thickness 0.2 mm hydrophobic PTFE filter, average pore size 8 µm
Sample Cell with wall mount bracket gas fittings sampling cell volume T <sub>63</sub> response time with 1 l/min sample flow weight	1/8" NPT, for 6 mm tubing 260 cm <sup>3</sup>  18 s 2.6 kg
Wetted materials	AISI 316L, Kalrez <sup>®</sup> Spectrum 6375, PTFE, SiN, MgF <sub>2</sub>

## Spare Parts and Accessories

**Table 20 Available Spare Parts and Accessories**

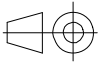


Spare Part	Order Code
Stainless steel net	216615
PTFE filter with Kalrez <sup>®</sup> O-ring	217056
Flange adapter with Kalrez <sup>®</sup> O-ring	217054
Wall mounting bracket	216653
Sample/Calibration cell with Kalrez <sup>®</sup>	216619
Cable gland	214728SP
Conduit fitting	217197
Kalrez <sup>®</sup> O-rings for sample cell/flange adapter	217199
Flange adapter gasket	216833
RS232C serial interface cable for PC	19446ZZ
RS232C-to-USB serial interface cable	219685

APPENDIX A  
**FLANGE PREPARATION  
INSTRUCTIONS**



**NOTE:**

WHEN ATTACHED TO PIPE WHOSE O.D. > Ø80 MM  
M5 HOLES MUST NOT BE BORED THROUGH TO  
PREVENT LEAKAGE FROM PROCESS.

				General tolerance ISO 2768-m	
	Arch id	SLD	Sheet	1/1	
					
	Scale	1:2			

# APPENDIX B

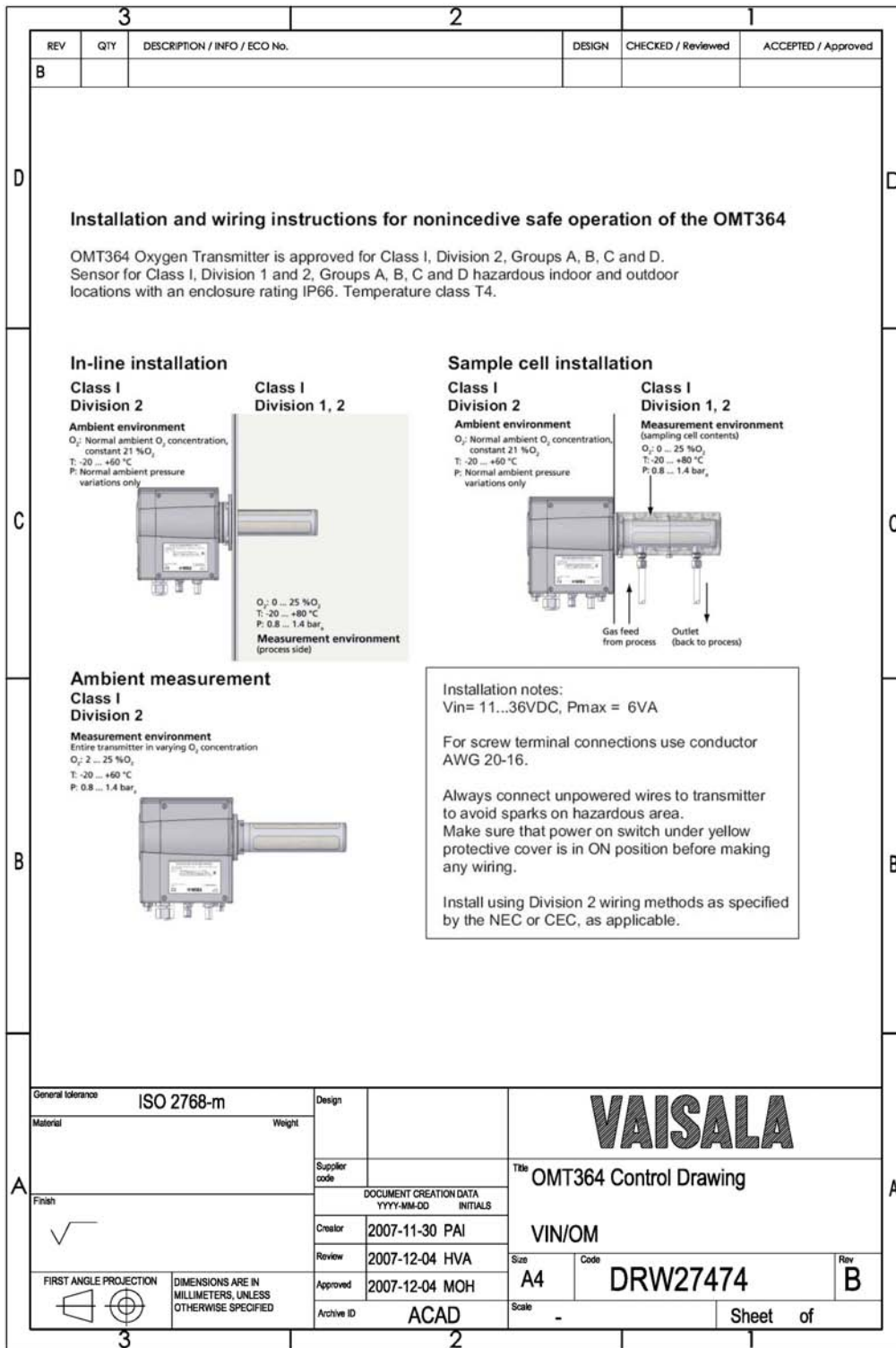
## HUMIDITY CONVERSION TABLE

Absolute humidity values in g/m<sup>3</sup> H<sub>2</sub>O

RH(%)	5	10	15	20	25	30	35	40	45	50	55	60	65	70	75	80	85	90	95	100
-40	0	0	0	0	0	0	0	0	0	0	0	0	0	0	0	0	0	0	0	0
-35	0	0	0	0	0	0	0	0	0	0	0	0	0	0	0	0	0	0	0	0
-30	0	0	0	0	0	0	0	0	0	0	0	0	0	0	0	0	0	0	0	0
-25	0	0	0	0	0	0	0	0	0	0	0	0	0	0	0	1	1	1	1	1
-20	0	0	0	0	0	0	0	0	0	1	1	1	1	1	1	1	1	1	1	1
-15	0	0	0	0	0	0	1	1	1	1	1	1	1	1	1	1	1	1	2	2
-10	0	0	0	0	1	1	1	1	1	1	1	1	1	2	2	2	2	2	2	2
-5	0	0	1	1	1	1	1	1	2	2	2	2	2	2	3	3	3	3	3	3
0	0	0	1	1	1	1	2	2	2	2	3	3	3	3	4	4	4	4	5	5
5	0	1	1	1	2	2	2	3	3	3	4	4	4	5	5	5	6	6	6	7
10	0	1	1	2	2	3	3	4	4	5	5	6	6	7	7	8	8	8	9	9
15	1	1	2	3	3	4	4	5	6	6	7	8	8	9	10	10	11	12	12	13
20	1	2	3	3	4	5	6	7	8	9	10	10	11	12	13	14	15	16	16	17
25	1	2	3	5	6	7	8	9	10	12	13	14	15	16	17	18	20	21	22	23
30	2	3	5	6	8	9	11	12	14	15	17	18	20	21	23	24	26	27	29	30
35	2	4	6	8	10	12	14	16	18	20	22	24	26	28	30	32	34	36	38	40
40	3	5	8	10	13	15	18	20	23	26	28	31	33	36	38	41	43	46	49	51
45	3	7	10	13	16	20	23	26	29	33	36	39	42	46	49	52	56	59	62	65
50	4	8	12	17	21	25	29	33	37	41	46	50	54	58	62	66	70	75	79	83
55	5	10	16	21	26	31	36	42	47	52	57	62	68	73	78	83	88	94	99	104
60	6	13	19	26	32	39	45	52	58	65	71	78	84	91	97	104	110	117	123	130
65	8	16	24	32	40	48	56	64	72	80	88	96	104	112	120	128	136	144	152	161
70	10	20	30	39	49	59	69	79	89	99	108	118	128	138	148	158	168	177	187	197
75	12	24	36	48	60	72	84	96	108	120	132	144	156	168	180	192	204	216	228	240
80	15	29	44	58	73	87	102	116	131	146	160	175	189	204	218	233	247	262	277	291



APPENDIX C  
**CONTROL DRAWINGS AND  
CERTIFICATES**



**Figure 32 OMT364 Control Drawing, FM**



FM Approvals  
 1151 Boston Providence Turnpike  
 P.O. Box 9102 Norwood, MA 02062 USA  
 T: 781 762 4300 F: 781-762-9375 www.fmapprovals.com

Member of the FM Global Group

## CERTIFICATE OF COMPLIANCE

### HAZARDOUS (CLASSIFIED) LOCATION ELECTRICAL EQUIPMENT

This certificate is issued for the following equipment:

**OMT3604abcdefghijklm. Oxygen Transmitter.**

Transmitter: NI / 1 / 2 / ABCD / T4 Ta = -20°C to 60°C; – DRW227474; IP66  
 Sensor: S / 1 / 1 / ABCD / T4 Ta = -20°C to 80°C; – DRW227474; IP66

a = Installation type: A, B or C  
 b = Filter type: 1, 2 or 3  
 c = Analog output range for oxygen: A, B, C, D, E or X  
 d = Signal output: 1 or 2  
 e = Fault state current for analog output: A or B  
 f = Relay settings: 1, 2 or 3  
 g = Cable bushing: A or B  
 h = In-situ calibration option: 1 or 2  
 i = Operating manual language: A or B  
 j = Certification: 1  
 k = Calibration/calibration contract: A  
 l = Additional maintenance: 1  
 m = Power supply unit: A

**Equipment Ratings:**

Transmitter: nonincendive for Class I, Division 2, Groups A, B, C and D, Ta = -20°C to +60°C

Sensor: suitable for Class I, Division 1, Groups A, B, C and D, Ta = -20°C to +80°C

Enclosure rating: IP66

**FM Approved for:**

Vaisala Oyj  
 Vantaa, Finland

FM Approvals HLC 6/07

3030766  
 Page 1 of 2

**Figure 33 US Certificate - Page 1**



This certifies that the equipment described has been found to comply with the following Approval Standards and other documents:

Class 3600	1998
Class 3611	2004
Class 3810	2005
ANSI/IEC 60529	2004

Original Project ID: 3030766                      Approval Granted: *June 19, 2009*

Subsequent Revision Reports / Date Approval Amended			
Report Number	Date	Report Number	Date

FM Approvals LLC

*J.E. Marquedant*  
\_\_\_\_\_  
J.E. Marquedant  
Group Manager, Electrical

*19 June 2009*  
\_\_\_\_\_  
Date

**Figure 34      US Certificate - Page 2**



FM Approvals  
1151 Boston Providence Turnpike  
P.O. Box 9102 Norwood, MA 02062 USA  
T: 781 762 4300 F: 781-762-9375 www.fmapprovals.com

## CERTIFICATE OF COMPLIANCE

### HAZARDOUS LOCATION ELECTRICAL EQUIPMENT PER CANADIAN REQUIREMENTS

This certificate is issued for the following equipment:

**OMT3604abcdefghijklm. Oxygen Transmitter.**

Transmitter: NI / 1 / 2 / ABCD / T4 Ta = -20°C to 60°C; – DRW227474; IP66  
Sensor: IPA / 1 / 1 / ABCD / T4 Ta = -20°C to 80°C; – DRW227474; IP66

a = Installation type: A, B or C  
b = Filter type: 1, 2 or 3  
c = Analog output range for oxygen: A, B, C, D, E or X  
d = Signal output: 1 or 2  
e = Fault state current for analog output: A or B  
f = Relay settings: 1, 2 or 3  
g = Cable bushing: A or B  
h = In-situ calibration option: 1 or 2  
i = Operating manual language: A or B  
j = Certification: 1  
k = Calibration/calibration contract: A  
l = Additional maintenance: 1  
m = Power supply unit: A

**Equipment Ratings:**

Transmitter: nonincendive for Class I, Division 2, Groups A, B, C and D, Ta = -20°C to +60°C

Sensor: suitable for Class I, Division 1, Groups A, B, C and D, Ta = -20°C to +80°C

Enclosure rating: IP66

**FM Approved for:**

Vaisala Oyj  
Vantaa, Finland

FM Approvals HLC 6/07

3030766C  
Page 1 of 2

**Figure 35 Canadian Certificate - Page 1**



This certifies that the equipment described has been found to comply with the following Approval Standards and other documents:

CSA C22.2 No. 213	1987
CSA C22.2 No. 61010-1	2004
CSA C22.2 No. 60529	2005

Original Project ID: 3030766

Approval Granted: 6/19/09

Subsequent Revision Reports / Date Approval Amended

Report Number	Date	Report Number	Date
---------------	------	---------------	------

FM Approvals LLC

  
\_\_\_\_\_  
J. E. Marquedant  
Group Manager, Electrical

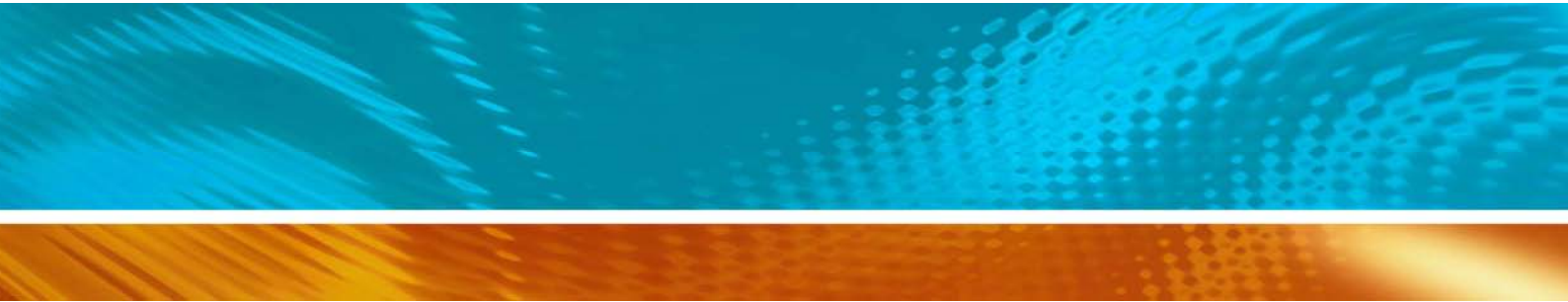
June 19, 2009  
Date

FM Approvals HLC 6/07

3030766C  
Page 2 of 2

**Figure 36 Canadian Certificate - Page 2**





[www.vaisala.com](http://www.vaisala.com)

