

OMT355 Oxygen Transmitter for Industrial Process Measurements



OMT355 with the sampling cell.

The Vaisala SPECTRACAP® Oxygen Transmitter.

Features/Benefits

- Minimizes need for sample conditioning equipment
- In-situ probe or sampling cell options
- Tolerates aggressive chemicals
- Tolerates excessive amounts of moisture even in liquid form
- Low maintenance
- Diagnostic output for preventive maintenance
- Heated optical surfaces to prevent condensation
- Typical applications:
 - gas generation
 - gas blanketing
 - fermentation
 - composting process monitoring

The Vaisala SPECTRACAP® Oxygen Transmitter OMT355 is ideal for oxygen monitoring in moist and aggressive process gases. Typical applications include gas generation, inert gas blanketing, fermentation and composting process monitoring.

Laser based measurement

The Vaisala SPECTRACAP® Oxygen Transmitter OMT355 is ideal for oxygen monitoring in moist and aggressive process gases. The OMT355 incorporates a compact tunable diode laser (TDL) gas spectrometer built in the measurement probe. This optical measurement technology is well known for unmatched stability and robustness. The SPECTRACAP® sensor offers TDL technology in a compact probe suitable for field use.

Direct installation

In many applications, the OMT355 can be flange-mounted directly into a process. No sampling or sample conditioning equipment is needed. This feature provides real time measurement data without sampling or sample switching delays.

Sampling cell installation

An optional sampling cell is available for processes with high temperatures, elevated pressures or extremely difficult mechanical conditions. Due to the robustness of the SPECTRACAP® sensor and its low sensitivity to gas flow and pressure variations, the sampling system can be very simple and it can be installed near the sampling point.

Low maintenance

A stainless steel mesh filter and an optional porous PTFE filter protect the OMT355 probe optics from dust and dirt. An intelligent measurement algorithm further minimizes contamination effects and provides a maintenance alert well before the measurement performance is affected.

Long calibration interval

Calibration or field checking of the instrument can be done either with ambient air or with zero/span

gases injected through an optional calibration gas connector. The calibration interval of the OMT355 is 12 months.

User friendly interfaces

For calibration and configuration, the OMT355 features both software and keypad user interfaces and an LCD display.

TDL Technology

The Tunable Diode Laser (TDL) technology used in the SPECTRACAP® sensor is one of the

most powerful technologies in gas measurement on the market today.

The technology is based on measuring the attenuation of a beam of laser light in the sample gas. For oxygen sensing the laser is tuned to a wavelength which is characteristic and unique for the oxygen molecule. Therefore, the measured attenuation is an extremely selective measure for the amount of oxygen on the path of the laser beam.

Technical data

Performance

Measurement range	0 ... 100 % O ₂
Accuracy (including noise, linearity, and repeatability)	±0.2 % O ₂
Temperature dependence over T range	±2 % of reading
Stability	±1 % of reading/yr
Zero drift	±0.1 % O ₂ /yr
Response time of measurement	3 s
Diffusion limited response in still air	T ₆₃ /T ₉₀
without filters	10 s / 20 s
with stainless steel mesh filter	10 s / 25 s
with stainless steel mesh and PTFE filters	30 s / 70 s
Pressure dependence without pressure compensation	
0.8 ... 1.2 bar	-2 % of reading
1.2 ... 1.4 bar	-5 % of reading
Accuracy of pressure compensation	±0.25 % of reading
Background gas effects for CO ₂ and H ₂ O, uncompensated	
<1 % of reading for <6 vol-% CO ₂	
<1 % of reading for gas dewpoint < 30 °C	
Accuracy of background gas compensation	
0 ... 50 vol-% CO ₂	±0.5 % of reading
0 ... 300 g/m ³ H ₂ O (T _d = 80 °C)	±1 % of reading

Operating Environment

Operating temperature range	
for probe (in-line installation)	-20 ... +80 °C
for electronics (housing)	-40 ... +60 °C
for transmitter (ambient gas measurement)	-20 ... +60 °C
Storage temperature range	-55 ... +80 °C
Operating pressure range	0.8 ... 1.4 bar
Maximum pressure range for probe	up to 10 bar
Compliance	
IEC(EN)-61326 Electrical equipment for measurement, control and laboratory use. EMC requirements	
EN50104 Electrical apparatus for the detection and measurement of oxygen. Performance requirements and test methods.	
EN50271 Electrical Apparatus for the Detection and Measurement of Combustible Gases, Toxic Gases or Oxygen	
Laser safety	Class 1 laser product

Inputs and Outputs

Power supply	
input range	11 ... 36 VDC
Power consumption	
maximum	6 W
typical	3 W
Analog output	0/4 ... 20 mA, sourcing
maximum load	500 Ω
Serial output (2-wire, non-isolated)	RS-485
Alarm/control relay	30 VAC/60 VDC

Technical data

Mechanics

Housing material	G-AISI10 Mg (DIN 1725)
Probe material	AISI 316
Housing classification	IP66
Dimensions	306 mm x 184 mm x 74 mm
Weight	2.2 kg
Mounting flange diameter	97 mm
Can be fitted to standard flanges. Minimum sizes:	
DIN (2527B) DN50 and ANSI (150) 2.5"	
Cable bushing	Cable gland M20 x 1.5
Stainless steel mesh filter	openings \varnothing 310 μ m
Wetted materials	AISI 316, EPDM or Kalrez [®] (optional), PTFE (optional), SiN, MgF ₂

Options and accessories

Hydrophobic PTFE filter, pore size 8 μ m	
with EPDM O-rings	217055
with Kalrez [®] O-rings	217056
1/2" NPT conduit fitting	217197
M12 male 8-pin connector for user cable	214806SP
Serial interface cable for PC	19446ZZ
USB-RJ45 Serial interface cable	219685
Sample cell with wall mounting bracket	
with EPDM O-rings	217052
with Kalrez [®] O-rings	216619

For complete specifications, refer to the User's Guide.

Dimensions

Dimensions in mm 306 mm x 184 mm x 74 mm

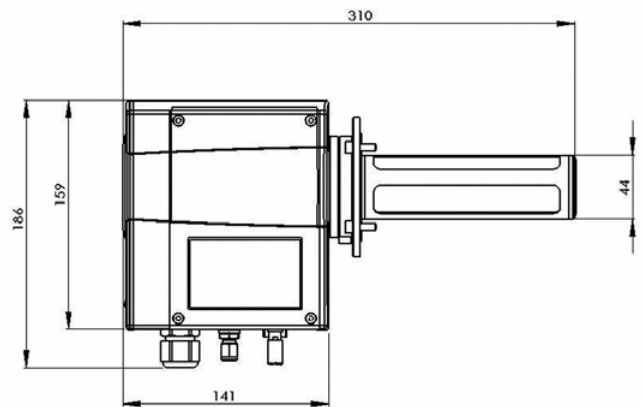
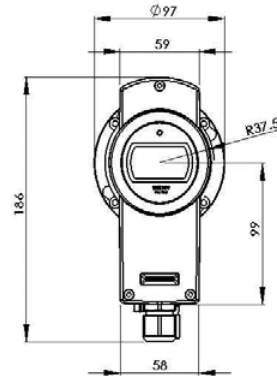

SPECTRACAP[®] is a registered trademark of Vaisala.

VAISALA

For more information, visit www.vaisala.com or contact us at sales@vaisala.com

Ref. B210623EN-C ©Vaisala 2010
 This material is subject to copyright protection, with all copyrights retained by Vaisala and its individual partners. All rights reserved. Any logos and/or product names are trademarks of Vaisala or its individual partners. The reproduction, transfer, distribution or storage of information contained in this brochure in any form without the prior written consent of Vaisala is strictly prohibited. All specifications — technical included — are subject to change without notice.

